

SHARP SERVICE MANUAL

S9505AYXPC9CUT

SPLIT TYPE ROOM HEAT PUMP

INDOOR UNIT	OUTDOOR UNIT
AY-XPC9CU	
AY-XPC12CU	
AY-XPC12CQ	AE-X3M24CU
AY-XPC18CU	
AY-XPC18CU-B	

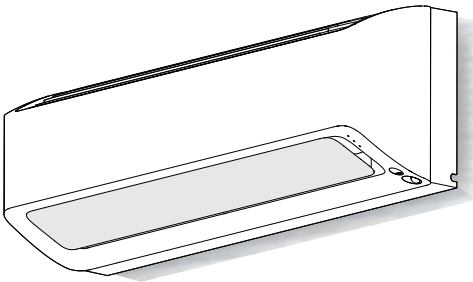

In the interests of user-safety (Required by safety regulations in some countries) the set should be restored to its original condition and only parts identical to those specified should be used.

CONTENTS

CHAPTER 1. PRODUCT SPECIFICATION

[1] SPECIFICATION	1-1
[2] EXTERNAL DIMENSION	1-3
[3] WIRING DIAGRAM	1-5
[4] ELECTRICAL PARTS	1-6

CHAPTER 2. EXPLANATION OF CIRCUIT AND OPERATION

[1] BLOCK DIAGRAMS	2-1
[2] MICROCOMPUTER CONTROL SYSTEM.....	2-3

CHAPTER 3. FUNCTION

[1] INDOOR UNIT FUNCTION	3-1
[2] OUTDOOR UNIT FUNCTION	3-4
[3] PAM CIRCUIT	3-5
[4] IPM DRIVE CIRCUIT.....	3-8

CHAPTER 4. FUNCTION AND OPERATION OF PROTECTIVE PROCEDURES

[1] PROTECTION DEVICE FUNCTIONS AND OPERATIONS.....	4-1
[2] HEAT PUMP OPERATION IN THERMISTOR ERROR	4-3
[3] THERMISTOR TEMPERATURE CHARACTERISTICS	4-4
[4] GENERAL TROUBLESHOOTING CHART	4-6
[5] MALFUNCTION (PARTS) CHECK METHOD ...	4-8

[6] OUTDOOR UNIT CHECK METHOD.....	4-10
[7] TROUBLESHOOTING GUIDE	4-12

CHAPTER 5. REFRIGERATION CYCLE

[1] SCHEMATIC DIAGRAM AND REFRIGERANT FLOW	5-1
[2] STANDARD CONDITION	5-1
[3] PEAK OPERATION CURRENT	5-1
[4] TEMPERATURE AT EACH PART AND PRESSURE IN STOP VALVE (GAS).....	5-2
[5] PERFORMANCE CURVES.....	5-4

CHAPTER 6. DISASSEMBLY PROCEDURE

[1] INDOOR UNIT (For AY-XPC9CU, AY-XPC12CU, AY-XPC12CQ models).....	6-1
[2] INDOOR UNIT (For AY-XPC18CU, AY-XPC18CU-B models)	6-6
[3] OUTDOOR UNIT	6-10

FAILURE DIAGNOSIS FLOW CHART
OPERATION MANUAL
INSTALLATION MANUAL
WLAN OPERATION MANUAL
PARTS LIST

Parts marked with "▲" are important for maintaining the safety of the set. Be sure to replace these parts with specified ones for maintaining the safety and performance of the set.

"Vertical louver (V-louver)" in this document means "horizontal air flow louver" in the operation manual.

"Horizontal louver (H-louver)" in this document means "vertical air flow louver" in the operation manual.

This document has been published to be used for after sales service only.
 The contents are subject to change without notice.

CHAPTER 1. PRODUCT SPECIFICATION**[1] SPECIFICATION**

ITEMS		MODEL		INDOOR UNIT	OUTDOOR UNIT
				AY-XPC9CU,AY-XPC12CU,AY-XPC12CQ, AY-XPC18CU,AY-XPC18CU-B	AE-X3M24CU
Rated cooling capacity (Min. - Max.) ☆		12CU × 3	Btu/h	24000 (5500 - 27000)	
Rated heating capacity (Min. - Max.) ☆		12CU × 3	Btu/h	26000 (8800 - 30000)	
Moisture removal (at cooling) ☆			pints/h	1.5×3	
Electrical data					
Phase			Single		
Rated frequency			Hz	60	
Rated voltage			V	208/230	
Rated current ☆	Cooling	A	7.8 *		
	Heating	A	7.8 *		
Rated input ☆	Cooling	W	1710 (300 - 2050)		
	Heating	W	1750 (550 - 2100)		
Power factor ☆	Cooling	%	94 *		
	Heating	%	95 *		
Compressor	Type		Twin rotary		
	Model		EKTM180D63UKZR		
	Oil charge	type cc	ESTER OIL VG75R 680		
Refrigerant system	Evaporator		Louver Fin and Grooved tube type		
	Condenser		Corrugate Fin and Grooved tube type		
	Control		Expansion valve		
	Refrigerant	type oz. (g)	R32 77.6 (2200)		
Sound Pressure Level (Cooling)			Full power/ High/ Low/ Soft/ Silent		52
	9CU	dB(A)	41/36/31/25/22		
	12CU, 12CQ		42/39/34/27/23		
	18CU, 18CU-B		45/43/38/31/28		
Sound Pressure Level (Heating)			Full power/ High/ Low/ Soft/ Silent		53
	9CU	dB(A)	42/37/32/26/22		
	12CU, 12CQ		43/40/35/28/23		
	18CU, 18CU-B		49/47/41/31/25		
Fan system					
Drive			Direct drive		
Fan speed (Cooling)			Full power/ High/ Low/ Soft/ Silent		810
	9CU	rpm	1000/900/750/600/500		
	12CU, 12CQ		1050/950/800/640/500		
	18CU, 18CU-B		1050/1000/850/650/550		
Fan speed (Heating)			Full power/ High/ Low/ Soft/ Silent		900
	9CU	rpm	1000/900/780/660/500		
	12CU, 12CQ		1050/950/820/700/500		
	18CU, 18CU-B		1200/1150/950/750/600		
Air flow quantity (Cooling)			Full power/ High/ Low/ Soft/ Silent		1501 (42.5)
	9CU	CFM(m3/min)	413(11.7)/360(10.2)/279(7.9)/198(5.6)/ 145(4.1)		
	12CU, 12CQ		438(12.4) /385(10.9)/307(8.7)/219(6.2)/ 145(4.1)		
	18CU, 18CU-B		636(18.0)/597(16.9)/480(13.6)/328(9.3)/ 251(7.1)		
Air flow quantity (Heating)			Super power/ High/ Low/ Soft/ Silent		1684 (47.7)
	9CU	CFM(m3/min)	413(11.7)/360(10.2)/297(8.4)/233(6.6)/ 145(4.1)		
	12CU, 12CQ		438(12.4)/385(10.9)/318(9.0)/254(7.2)/ 145(4.1)		
	18CU, 18CU-B		752(21.3)/713(20.2)/558(15.8)/403(11.4)/ 290(8.2)		
Fan			Cross flow fan Φ108mm		Propeller fan

Connections			
Refrigerant coupling			Flare type
Refrigerant tube size (Gas line)		inch (mm)	3/8 (9.52)
Refrigerant tube size (Liquid line)		inch (mm)	1/4 (6.35)
Minimum - Maximum length (per unit)		ft (m)	10 - 82 (3 - 25)
Maximum length	3 units	ft (m)	230 (70)
Maximum charge-less length		ft (m)	98 (30)
Maximum height difference(IDU&ODU, IDU&IDU)		ft (m)	49 (15) , 33(10)
Additional charge		oz./ft (g/m)	0.11 (10)
Drain pipe O.D.		inch (mm)	0.7 and 0.8 (17 and 20)
Others			
Safety device		Compressor: Thermal protector	
		Fan motors: Thermal fuse	
		Fuse, Micro computer control	
Air fillters		Polypropylene net (Washable)	
Net dimensions		Width / Height / Depth	
	9CU	inch (mm)	34 39/64 / 11 3/8 / 9 1/64 (879 / 289 / 229)
	12CU, 12CQ		34 39/64 / 11 3/8 / 9 1/64 (879 / 289 / 229)
	18CU, 18CU-B		41 27/64 / 12 7/16 / 9 51/64 (1052 / 316 / 249)
			33 15/32 / 27 15/16 / 13 (850 / 710 / 330)
Net weight	9CU	lb. (kg)	22 (10)
	12CU, 12CQ		22 (10)
	18CU, 18CU-B		31 (14)
			115 (52)

NOTE: Test conditions are based on AHRI 210/240. (Refrigerant piping length [per unit] : 25ft[7.6m])

* : Voltage is 230V ☆ : Representative connection

AE-X3M24CU

Cooling Capacity Table

Operating Status	Indoor unit combination			Cooling capacity (Btu/h)				Power input (W) Rating (Min. - Max.)	Running current (A) Rating (Min. - Max.)	
	A	B	C	A	B	C	Rating (Min. - Max.)		208V	230V
	3-indoor unit operation	12	12	12	8,000	8,000	8,000		24,000 (5,500 - 27,000)	1,710 (300 - 2,050)
12		12	9	8,727	8,727	6,545	24,000 (5,500 - 27,000)	1,710 (300 - 2,050)	8.6 (2.0 - 10.2)	7.8 (1.8 - 9.2)
12		9	9	9,600	7,200	7,200	24,000 (5,500 - 27,000)	1,710 (300 - 2,050)	8.6 (2.0 - 10.2)	7.8 (1.8 - 9.2)
9		9	9	8,000	8,000	8,000	24,000 (5,500 - 27,000)	1,710 (300 - 2,050)	8.6 (2.0 - 10.2)	7.8 (1.8 - 9.2)
2-indoor unit operation	18	18	-	12,000	12,000	-	24,000 (5,500 - 27,000)	1,710 (330 - 2,050)	8.6 (2.2 - 10.2)	7.8 (2.0 - 9.2)
	18	12	-	14,400	9,600	-	24,000 (5,500 - 27,000)	1,710 (330 - 2,050)	8.6 (2.2 - 10.2)	7.8 (2.0 - 9.2)
	18	9	-	16,000	8,000	-	24,000 (5,500 - 27,000)	1,710 (330 - 2,050)	8.6 (2.2 - 10.2)	7.8 (2.0 - 9.2)
	12	12	*	11,000	11,000	*	22,000 (5,000 - 24,000)	1,710 (330 - 2,050)	8.6 (2.2 - 10.2)	7.8 (2.0 - 9.2)
	12	9	*	12,571	9,429	*	22,000 (5,000 - 24,000)	1,710 (330 - 2,050)	8.6 (2.2 - 10.2)	7.8 (2.0 - 9.2)
	9	9	*	9,500	9,500	*	19,000 (5,000 - 22,000)	1,400 (330 - 1,800)	7.0 (2.2 - 9.0)	6.4 (2.0 - 8.1)
1-indoor unit operation	18	*	-	18,000	*	-	18,000 (4,200 - 21,000)	1,710 (350 - 1,880)	8.6 (2.3 - 9.4)	7.8 (2.1 - 8.5)
	12	*	*	12,000	*	*	12,000 (4,200 - 13,000)	1,080 (350 - 1,180)	5.4 (2.3 - 5.9)	4.9 (2.1 - 5.3)
	9	*	*	9,000	*	*	9,000 (4,200 - 10,600)	780 (350 - 860)	3.9 (2.3 - 4.3)	3.5 (2.1 - 3.9)

* When connected indoor unit is not in operation.
- When no unit is connected.

Heating Capacity Table

Operating Status	Indoor unit combination			Heating capacity (Btu/h)				Power input (W) Rating (Min. - Max.)	Running current (A) Rating (Min. - Max.)	
	A	B	C	A	B	C	Rating (Min. - Max.)		208V	230V
	3-indoor unit operation	12	12	12	8,667	8,667	8,667		26,000 (8,800 - 30,000)	1,750 (550 - 2,100)
12		12	9	9,455	9,455	7,091	26,000 (8,800 - 29,400)	1,750 (550 - 2,100)	8.6 (3.6 - 10.5)	7.8 (3.3 - 9.5)
12		9	9	10,400	7,800	7,800	26,000 (8,800 - 29,000)	1,750 (550 - 2,100)	8.6 (3.6 - 10.5)	7.8 (3.3 - 9.5)
9		9	9	8,667	8,667	8,667	26,000 (8,800 - 28,600)	1,750 (550 - 2,100)	8.6 (3.6 - 10.5)	7.8 (3.3 - 9.5)
2-indoor unit operation	18	18	-	13,000	13,000	-	26,000 (9,400 - 29,400)	1,750 (550 - 2,100)	8.6 (3.6 - 10.5)	7.8 (3.3 - 9.5)
	18	12	-	15,600	10,400	-	26,000 (9,400 - 29,000)	1,880 (600 - 2,200)	9.3 (3.9 - 11.0)	8.4 (3.6 - 9.9)
	18	9	-	17,333	8,667	-	26,000 (9,400 - 29,000)	1,880 (600 - 2,200)	9.3 (3.9 - 11.0)	8.4 (3.6 - 9.9)
	12	12	*	13,000	13,000	*	26,000 (8,800 - 28,600)	2,240 (700 - 2,650)	11.0 (4.6 - 13.2)	10.0 (4.2 - 11.9)
	12	9	*	13,371	10,029	*	23,400 (8,800 - 28,600)	1,900 (700 - 2,650)	9.4 (4.6 - 13.2)	8.5 (4.2 - 11.9)
	9	9	*	10,100	10,100	*	20,200 (8,800 - 28,600)	1,500 (700 - 2,650)	7.4 (4.6 - 13.2)	6.7 (4.2 - 11.9)
1-indoor unit operation	18	*	-	23,000	*	-	23,000 (8,000 - 26,000)	2,060 (600 - 2,450)	10.2 (3.9 - 12.2)	9.2 (3.6 - 11.0)
	12	*	*	15,000	*	*	15,000 (4,500 - 18,000)	1,580 (600 - 2,150)	7.8 (3.9 - 10.7)	7.1 (3.6 - 9.7)
	9	*	*	11,000	*	*	11,000 (4,500 - 13,000)	1,020 (600 - 1,380)	5.1 (3.9 - 6.9)	4.6 (3.6 - 6.2)

* When connected indoor unit is not in operation.
- When no unit is connected.

[2] EXTERNAL DIMENSION

1. Indoor unit

AY-XPC9CU, AY-XPC12CU, AY-XPC12CQ

Length unit: mm

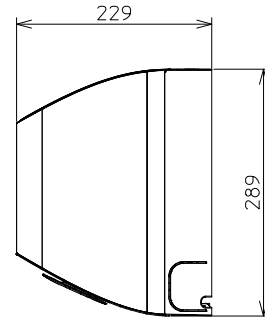
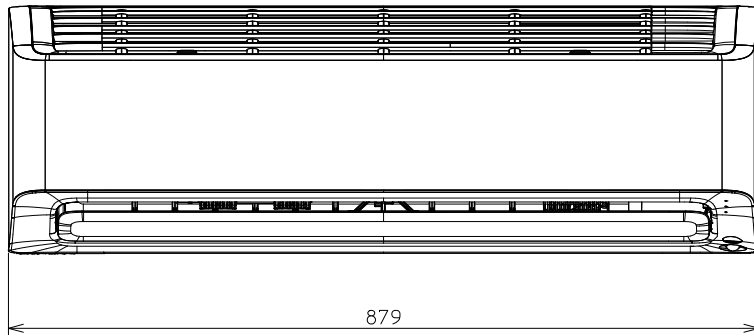
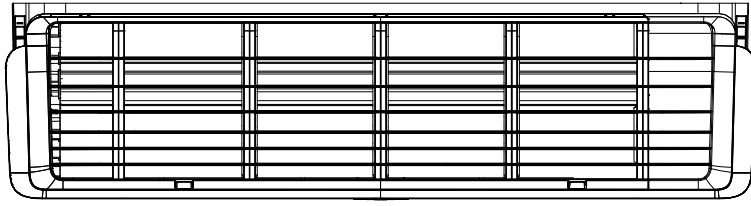

AY-XPC18CU, AY-XPC18CU-B

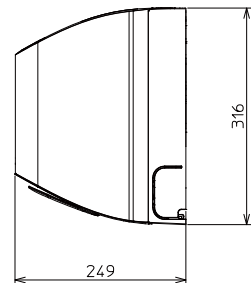

2. Outdoor unit

Length unit: inch (mm)

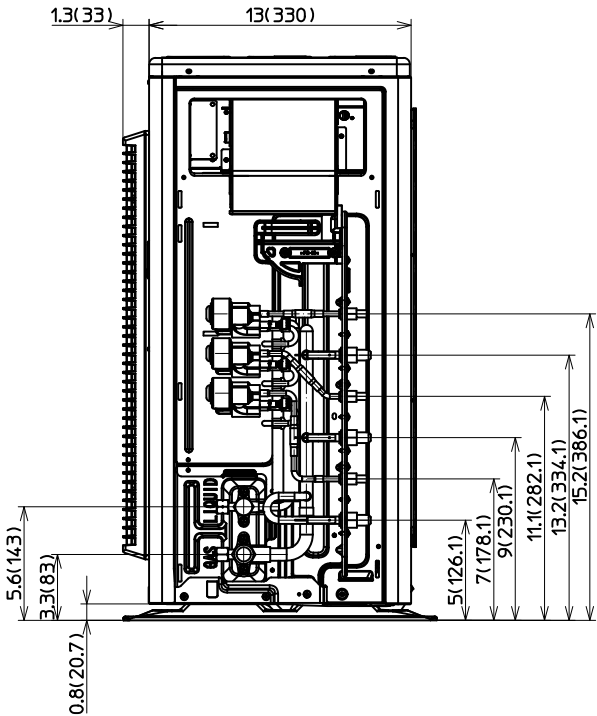
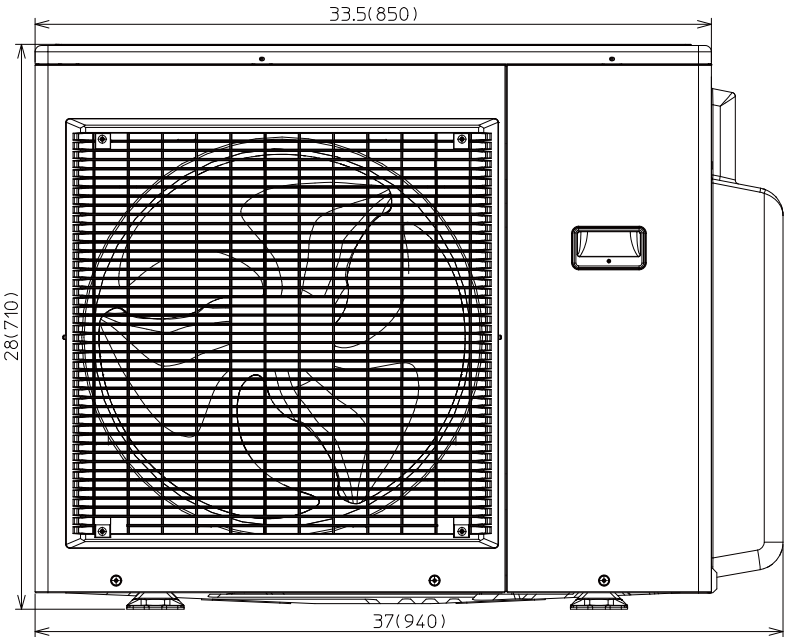
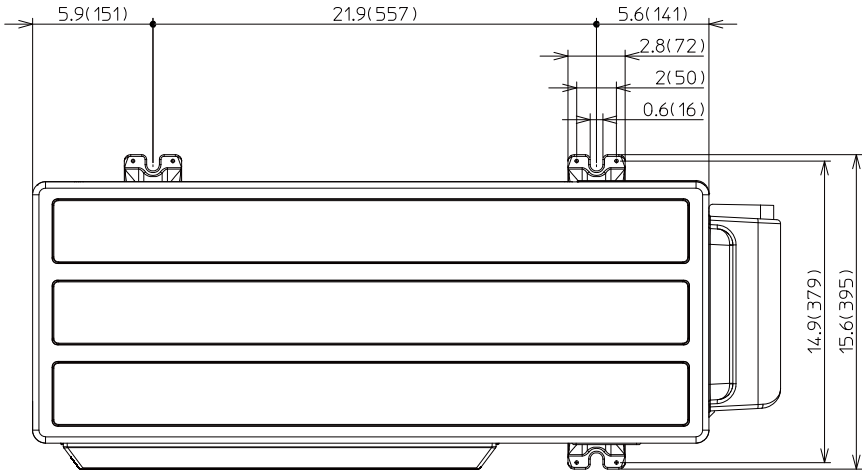

[3] WIRING DIAGRAM

1. Indoor unit

LED INDICATION FOR SELF-DIAGNOSIS <Indication of the abnormal condition>
LED indicator will blink, if the set is in abnormal condition.

Definition for only Main No. code(Please refer to the service manual for more detail)			
Press down ON/OFF button for 5 seconds while the sets is standing by.	1	Short circuit of outdoor unit thermistor	
	2	Overheat error (compressor or cycle)	
	3	Temporary stop due to dehumidifying operation	
	5	Open circuit of outdoor unit thermistor	
	6	DC over current error	
	7	AC over current error/AC current abnormal	
Definition for error code: Operation Lamp(Gr): Main No.(tens digit) Timer Lamp(Ye): Main No.(units digit) WiFi Lamp/Error Lamp(Gr): Sub No.	8	Abnormal wire check	
	9	Thermistor installation error/4 way valve error or gas leak error	
	10	EEPROM/CPU error of outdoor unit	
	11	Abnormal outdoor fan motor	
	12	Thermal fuse error of terminal board	
	13	Abnormal compressor rotation	
	14	DC voltage/power supply voltage error	
	17	Open-circuit of serial signal line/erroneous wiring	
	18	Short-circuit of serial signal line/erroneous wiring	
	19	Abnormal indoor fan motor	
	20	EEPROM error of indoor unit	
	24	Abnormal Wireless LAN(Wireless adapter is optional)	
	26	Open-circuit/short-circuit of indoor thermistor	

Example:

Lamp	Main No.	Sub No.	Error code	
	Gr	Ye	Gr	
Times of blinking	1	4	2	14-2
	0	9	4	9-4

WIRING DIAGRAM

SOME FUNCTIONS ARE OPTIONAL DEPENDING ON DIFFERENT MODELS. CE518

2. Outdoor unit

WIRING DIAGRAM

CAUTION The voltage is high at C(electric capacitors) on outdoor unit. For maintenance, discharge at C to prevent electric shock.If the fuse FUS has blown out, the voltage is kept high at C. Usually LED shows that the charge of C is still high, too.

LED INDICATION OF SELF-DIAGNOSIS ON OUTDOOR UNIT

LED BLINKING

- LED turns on
- Slow flashing (1 time for 1 second)
- Quick flashing (3 times for 1 second)

No. LED pattern	Abnormal comments
Normal	Normal
1	Abnormal signal line
2	Short circuit of the thermistor
3	Overheat error (Compressor, Power module)
4	Open circuit of the thermistor
5	Power module(IPM) abnormality
6	Abnormal AC current
7	Abnormal wire check
8	Cycle temperature error
9	EEPROM error
10	Rotation error of the fan motor
11	Thermal fuse error of terminal board
12	Compressor rotation error
13	PAM voltage or PAM clock error

Example: No.3 Overheat error (Compressor, Power module)

The LEDs of the display board will all flash synchronously. For patterns No.1, No.2 and No.4, only the LED corresponding with the abnormal unit will flash in the patterns above, and the LED for the normal unit will flash in the slow flashing cycle.

WIRING LAYOUT OF CONTROL UNIT

COMPONENT SIDE VIEW

SOLDER SIDE VIEW

Terminal connection mode of compressor

RECH (RED C 10)
WT 5 (WT 5 (10))
GMCC (WT 20 (10))
RED V (10)
OR 5 (10)

[4] ELECTRICAL PARTS**1. Indoor unit**

DESCRIPTION	MODEL	REMARKS
Indoor fan motor	DAI239P-H030A-3207/ZKFP-30-8-277L	30W,Class E
Transformer	TE20SMSW-G08V/BCK-19-0701	DC 5V,12V,19V
Fu1	2010 T3.15A 250V	3.15A,250V

2. Outdoor unit

DESCRIPTION	MODEL	REMARKS
Compressor	EKTM180D63UKZR	DC 229V at 180Hz, 12-120rps,R32,1430W
Outdoor fan motor	DBI445P-L041A-AL01-1	280V 41W 8P
Fu5, Fu1	-	250V 20A
Fu2	-	250V 3.15A
Fu3	-	250V 2A

CHAPTER 2. EXPLANATION OF CIRCUIT AND OPERATION

[1] BLOCK DIAGRAMS

1. Indoor unit

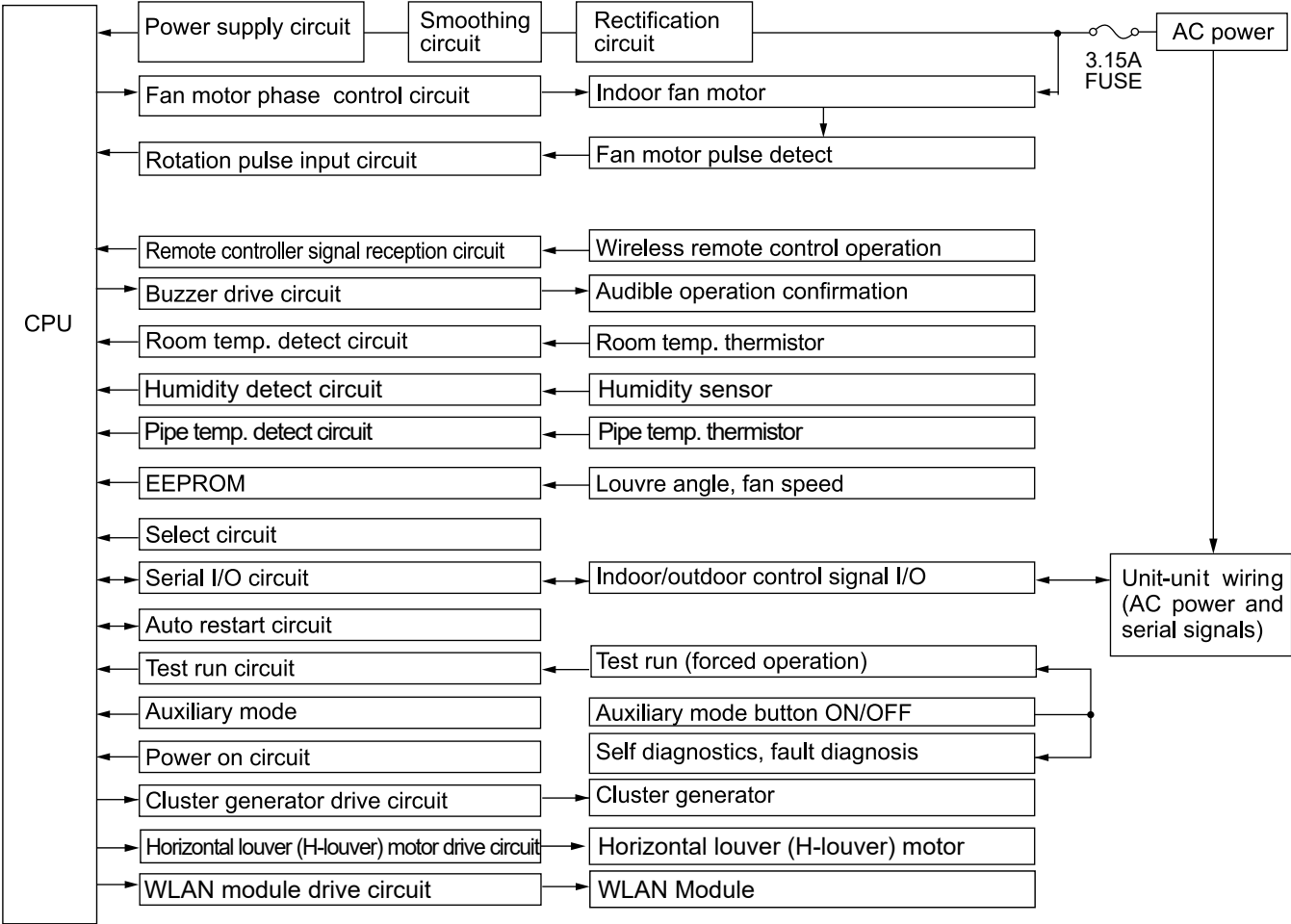

2. Outdoor unit

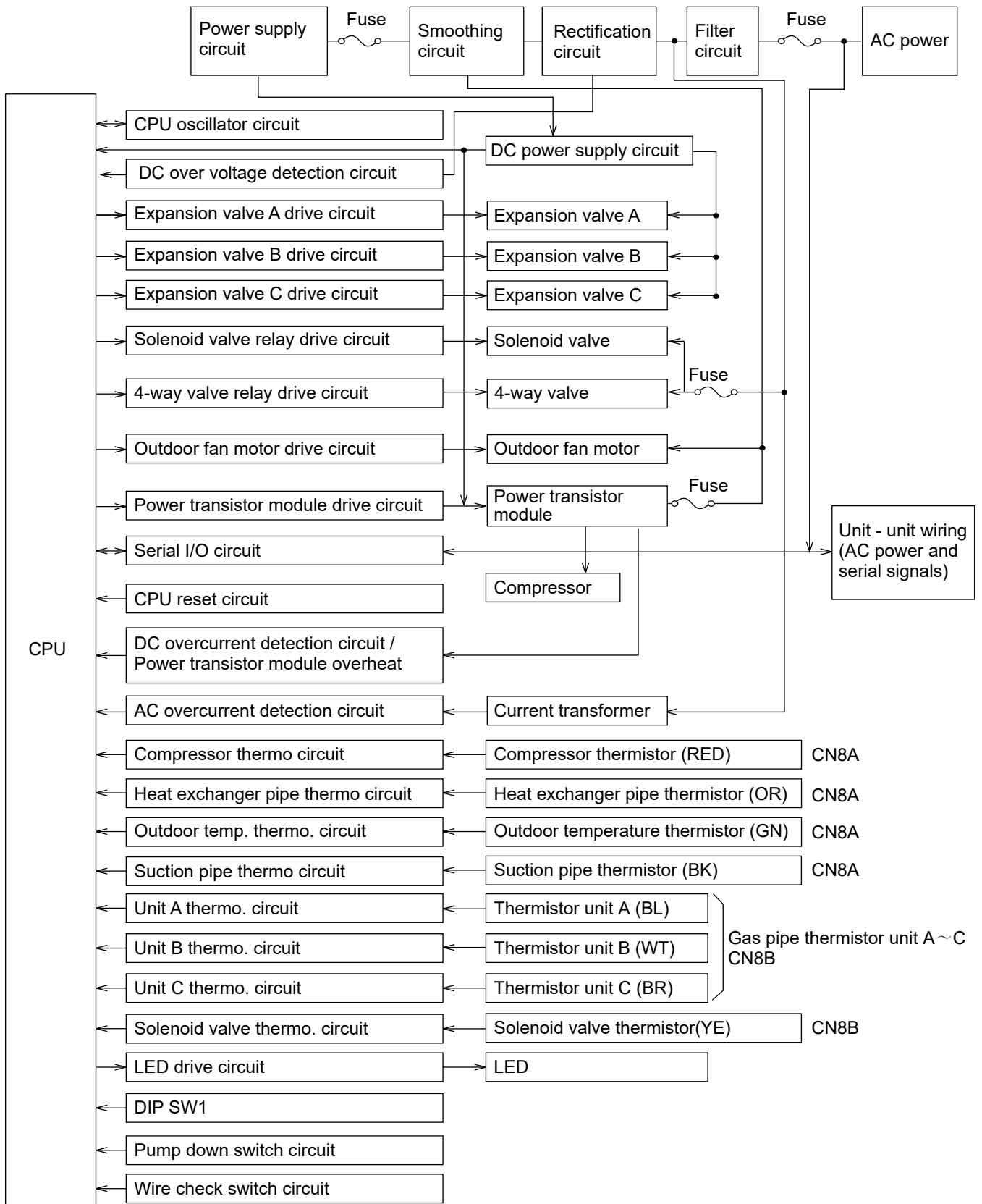

2.Outdoor unit

2.1. Printed wiring board

If the outdoor main board is replaced with a service board, be sure to perform a wire check.

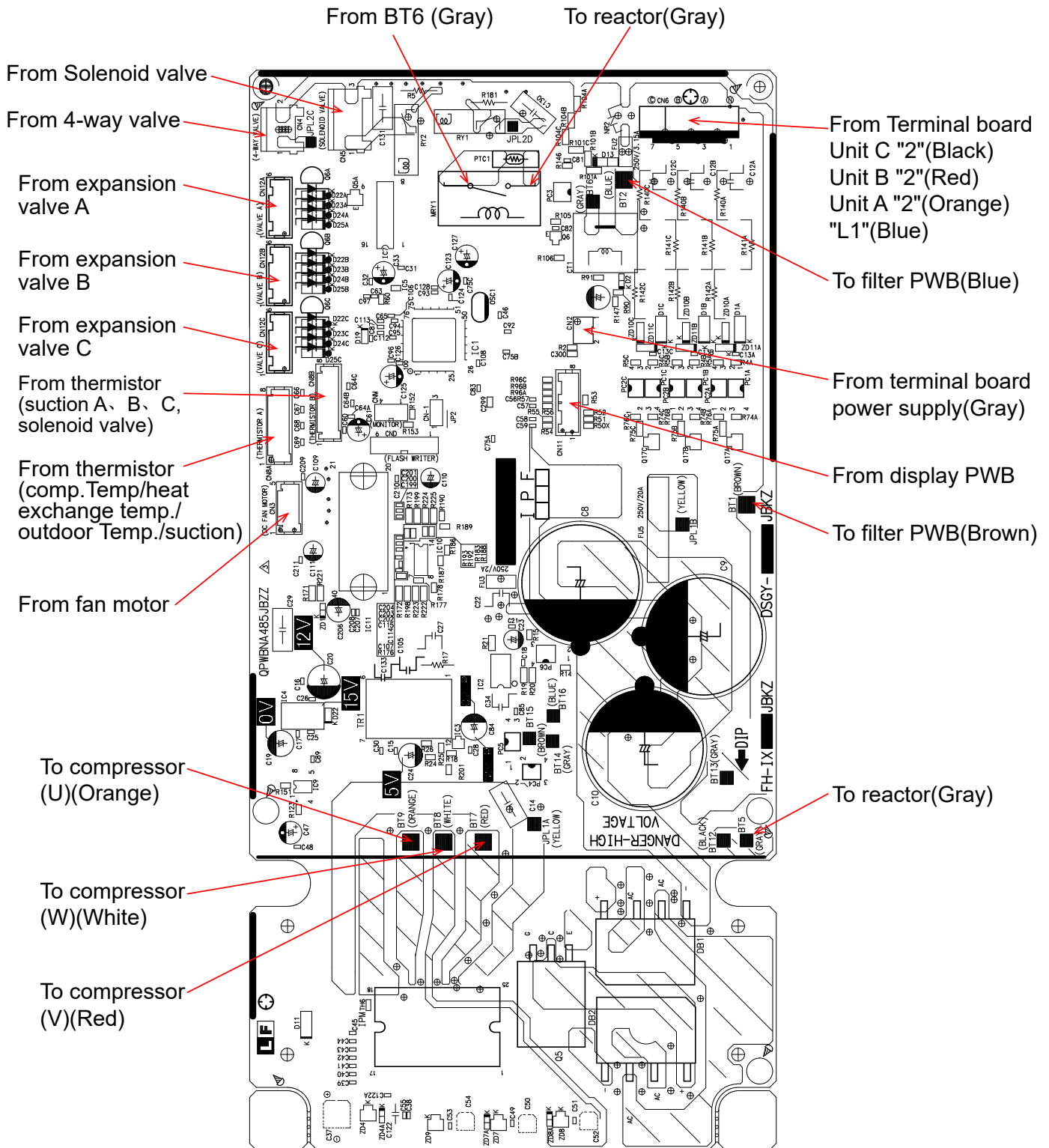

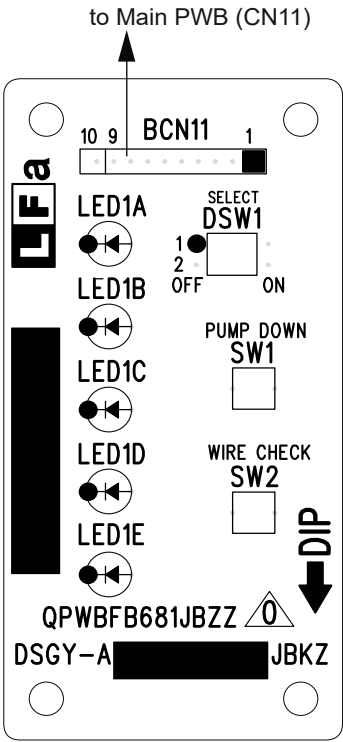
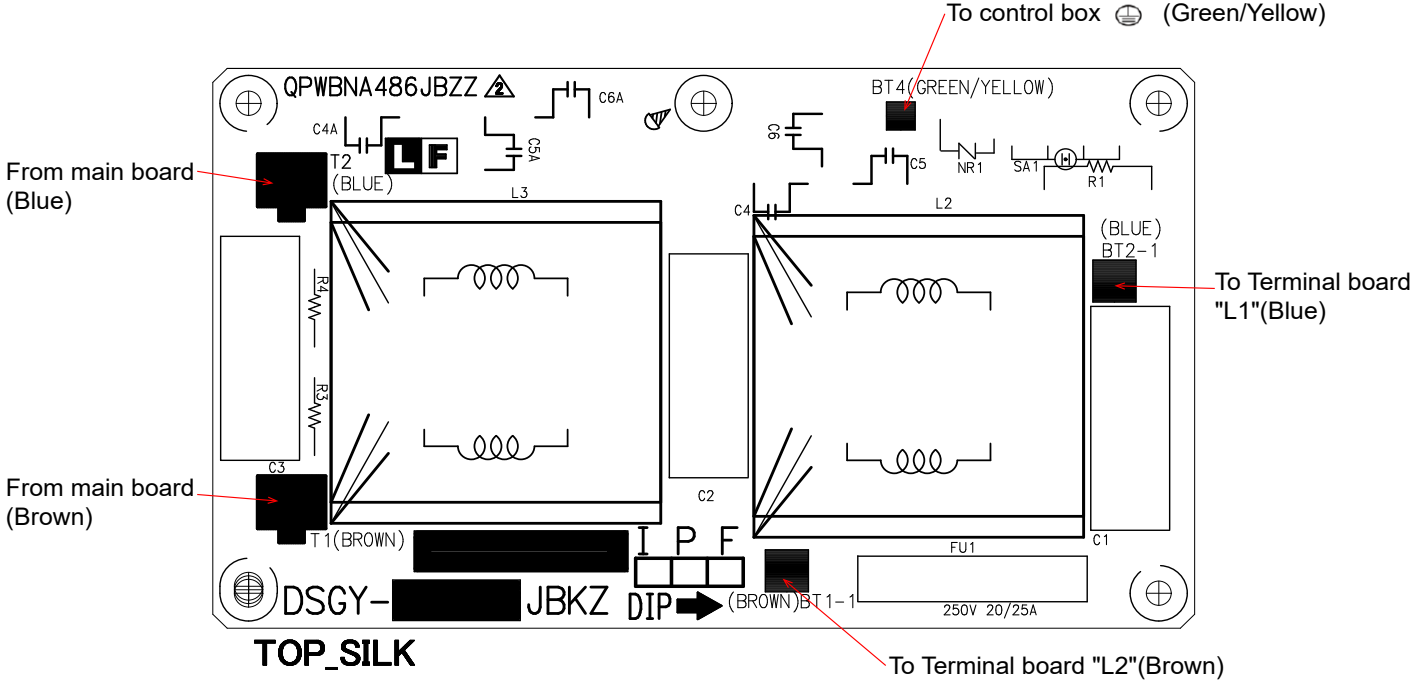

CHAPTER 3. FUNCTION

[1]Indoor unit function

1 Restart control

Once the compressor stops operating, it will not restart for 180 seconds to protect the compressor.

Therefore, if the operating compressor is shut down from the remote control and then turned back on immediately after, the compressor will restart after a preset delay time.

(The indoor unit will restart operation immediately after the ON switch is operated on the remote control.)

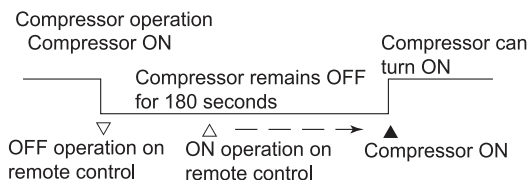

2. Startup control

The compressor always runs at its maximum frequency at the start of:
 -cooling mode and when the room temperature is 3°C higher than the set temperature.

-heating mode and when the room temperature is 3°C lower than the set temperature.

-heating mode of a unit connected as multi zone system, until the heat exchanger reaches 35°C and also the compressor operates more than 2 minutes at the maximum frequency.

When the room temperature reaches to the set temperature, the compressor runs at an inverter-controlled frequency.

3. Indoor unit heat exchanger freeze prevention control

If the temperature of the indoor unit heat exchanger remains below 0°C for 4 consecutive minutes during cooling or dehumidifying operation, the compressor operation stops temporarily in order to prevent freezing. When the temperature of the indoor unit heat exchanger rises to 2°C or higher after about 180 seconds, the compressor restarts and resumes normal operation.

The freeze prevention control of the liquid pipe: the unit will stop compressor when the temperature of the liquid pipe is below 0°C for 7 minutes. The compressor will restart after the temperature of the liquid pipe rises to 2°C. When using the unit as multi zone system and other connected units are running normally, the compressor will not stop.

4 ON timer

The ON timer can be activated by pressing the ON timer button. When the ON timer is activated, the operation start time is adjusted based on fuzzy logic calculations 2 hour before the set time so that the room temperature reaches the set temperature at the set time.

5. OFF timer

The OFF timer can be activated by pressing the OFF timer button. When the OFF timer is activated, the internal timer start to count down the remaining time from set time. And the unit will turn off automatically when it reach to zero.

6. Power ON start

If the connecting wire HAJP is put on the PWB assembly, when the power is supplied by turning on a circuit breaker, the heat pump automatically starts of operation in "AUTO". (Refer to Indoor side PWB).

7. AUTO MODE

When two or more indoor units are used in multi-split system, any subsequent unit set to AUTO mode will operate in the same mode as the first unit. In this situation, Auto Change Over function is disabled.

1) AUTO mode of ON/OFF button

In the AUTO mode, the temperature setting and mode are automatically selected according to the room temperature and outdoor temperature when the unit is turned on.

Modes and Temperature Settings

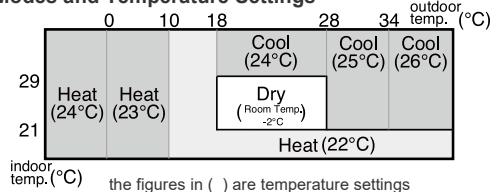

During operation, if the outdoor temperature changes, the temperature settings will automatically slide as shown in the chart.

2) AUTO mode of remote control

In the AUTO mode, the unit selects operating mode (Heating/ Cooling) according to temperature setting which set by user and room temperature.

Additionally, the Auto Change Over function will switch between cooling and heating if the compressor stays off for a long time(11-15 minutes).

8. Difference of operation in Auto and Manual modes

In the Auto mode of ON/OFF button, the temperature setting is automatically determined based on the outside air temperature.

8.1 Difference relating to set temperature

		Temperature setting method
Auto mode (by pressing ON/OFF button)	Heat	Automatic temperature setting based on outside air temperature.
	Cooling	
Auto mode (set by remote control)	Heat	Can be changed between 16~30°C using remote control.
	Cooling	
Manual mode	Heat	Can be changed between 16~30°C using remote control.
	Cooling	

9. Operating temperature range

The built-in protective device may prevent the unit from operating when used out of this range.

lowest operating temperature for HEAT	
-17°F(-27°C)	For AY-XPC12CU/CQ
-22°F(-30°C)	Except for AY-XPC12CU/CQ

If outdoor temperature can drop below lowest operating temperature for HEAT in your area, we recommend you to have another heating source.

When outdoor temperature actually drops below lowest operating temperature for HEAT, OPERATION indicator (green), TIMER indicator (orange), and WLAN indicator (green) on the unit will blink continuously. Turn off the unit to prevent any damages, as well as inefficient performance.

You can activate Auto cut off at lowest operating temperature for HEAT by setting DIP switch position (DSW1:from OFF to ON).

10. Dehumidifying operation control

DRY mode are available through Sharp Air App.

The setting temperature is determined by outdoor temperature and room temperature at the start of operation.

Room temperature at the start of operation is under 26°C	
outdoor temperature (°C)	Setting temperature
under 22	room temperature+0.3°C
22~25	room temperature±0°C
25~28	room temperature -1°C
over 28	room temperature -1.7°C

Room temperature at the start of operation is over 26°C	
outdoor temperature (°C)	Setting temperature
under 18	23°C
18~28	24°C
28~31	25°C
31~34	26°C
34~37	27°C
over 37	28°C

11. Full Power Operation

In this operation, the air/air heat pump works at the maximum power and optimum louver direction to make the room cool or warm rapidly. During operation, press the FULL POWER button.

- The remote control will display “”

TO CANCEL

Press the FULL POWER button again.

- The FULL POWER operation will also be cancelled when the operation mode is changed, or when the unit is turned off.

NOTE:

- The air/air heat pump will operate at “Extra HIGH” fan speed, the vertical adjustment louver will be set obliquely downward during full power operation. The full power operation will stop after 15 minutes.
- You can not set the temperature or fan speed during the FULL POWER operation.
- If the set temperature is close to the room temperature, the power may not be at maximum.

12. After Care (Auto and Manual)

Heating or Fan operation and Cluster operation are performed simultaneously.

The heating will be operated after the fan operation.

If the outside temperature or room temperature is high, heating operation may not be performed.

The operation time is 70-90 minutes.

When fan is operated, the louver will move horizontally.

When heating is operated, the louvers move above horizontal position.

13. Plasmacluster Ion function

Plasmacluster ion generator is set to ON by default and Plasmacluster ions are released during any mode of operation. (You can change the ion setting from Menu.)

- “Plasmacluster operation” generates about equal amounts of (+) ions and (-)ions from the cluster unit to provide clean air.

If the Plasmacluster Ion generation function is operated together with the heat pump operation, the indoor unit fan speed and louver direction are in accordance with the heat pump settings.

14. Explanation of cluster circuit

The cluster unit generates cluster ions, which are circulated throughout the room by the air flow created by the blower fan (indoor unit fan motor) in the heat pump unit.

- 1) When microcomputer output turns “H,” the Q2 output changes to “Lo,” applying 12 V voltage to the cluster unit for the generation of cluster ions (positive and negative ions).

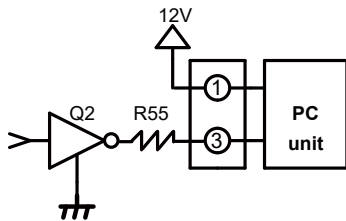

15. Auto restart

When power failure occurs during operation after power is recovered, the unit will automatically restart in the same setting which were active before the power failure.

1) Setting memorized

- Operating mode (COOL, HEAT, AUTO, FAN, DRY)
- Temperature setting
- Fan setting
- Air flow direction
- Power ON/OFF
- Automatic operation mode setting
- Plasmacluster Ions setting
- SPOT setting
- ECO setting
- OD silent setting

2) Setting not memorized

- Timer setting
- Full power setting
- After care operation
- Multi Space setting

3) Disabling auto restart function

By removing (cutting) jumper (JP0) on the printed circuit board(PCB), the auto restart function can be disabled.

15. Save operation (Only for the CHU Series)

This control is valid only in ECO mode.
 If there is no person for 1 hour, the heat pump will arise setting temperature.
 If a person is detected, correction temperature will be restored.

Limit of Temperature

Cool	
Correction Temperature Limit	+1.0°C
Heat	
Correction Temperature Limit	-1.0°C

e.g

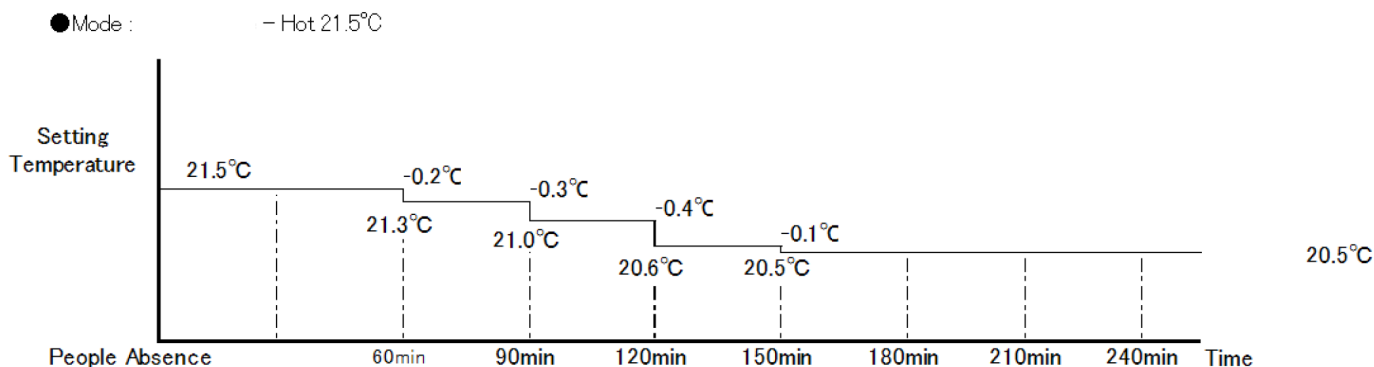
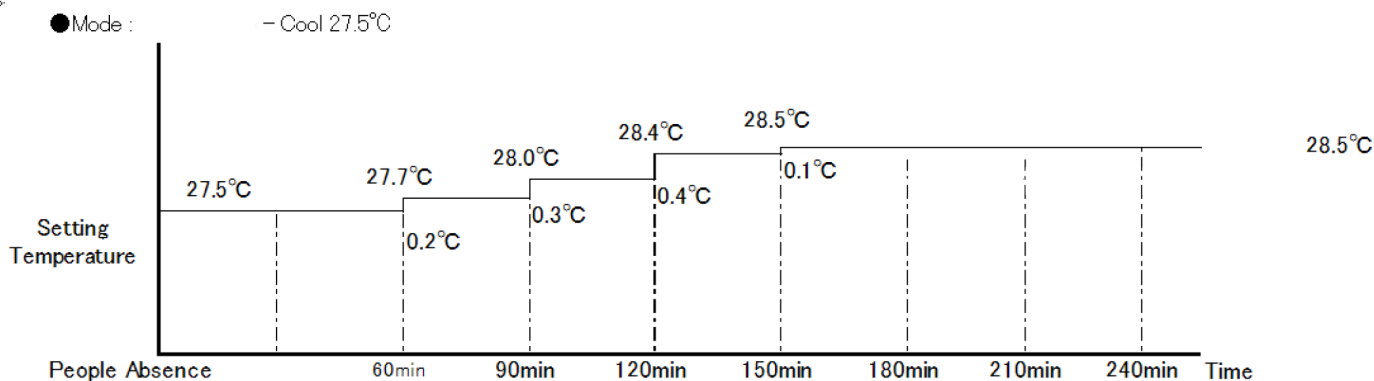

16. Activity Detection (Only for the CHU Series)

This control is valid only in ECO mode. If the amount of human activity increases for few minutes, setting temperature is lowered, fan rotation is increased by 100rpm when fan setting is ECO, and horizontal louver (H-louver) is turned downward when the louver setting is ECO. If a person's activity decreases, it is returned to original state.

Setting temperature is corrected lower by the amount of human activity as following.

temperature correction table		temperature correction degree		
		activity weak	activity mid	activity strong
room temperature(°C)	28~	1	1.75	2.5
	26~28	1	1.5	2
	24~26	0.5	1	1.5
	22~24	0.25	0.75	1.25
	17~22	0.25	0.5	0.75
	~17	0	0	0

[2]Outdoor unit function

1. Restart control

Once the compressor stops operating, it will not restart for 180 seconds to protect the compressor.

Therefore, if the operating compressor is shut down from the remote control and then turned back on immediately after, the compressor will restart after a preset delay time.

(The indoor unit will restart operation immediately after the ON switch is operated on the remote control.)

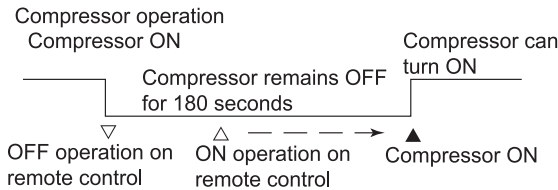

2. Outdoor unit 2-way valve freeze prevention control

If the temperature of the outdoor unit 2-way valve remains below 0°C for 10 consecutive minutes during cooling or dehumidifying operation, the compressor operation stops temporarily in order to prevent freezing.

When the temperature of the 2-way valve rises to 10°C or higher after about 180 seconds, the compressor restarts and resumes normal operation.

3. Outdoor unit overheat prevention control

During cooling operation, if the temperature of the outdoor unit heat exchanger exceeds the outdoor unit heat exchanger overheat prevention temperature (about 55°C), the operating frequency is decreased by about 4 to 15 Hz. Then, this operation is repeated every 60 seconds until the temperature of the outdoor unit heat exchanger drops to about 54°C or lower.

Once the temperature of the outdoor unit heat exchanger drops to about 54°C or lower, the operating frequency is increased by about 4 to 10 Hz every 60 seconds until the normal operation condition resumes.

If the temperature of the outdoor unit heat exchanger exceeds the outdoor unit heat exchanger overheat protection temperature for (120 sec. : outdoor temperature ≥ 40°C, 60 sec. : outdoor temperature < 40°C) at minimum operating frequency, the compressor stops operating and then restarts after about 180 seconds, and the above mentioned control is repeated.

4. Compressor overheat prevention control

If the temperature of the compressor exceeds the compressor overheat prevention temperature (110°C), the operation frequency is decreased by about 4 to 10 Hz. Then, this operation is repeated every 60 seconds until the temperature of the compressor drops below the overheat protection temperature (110°C).

Once the temperature of the compressor drops below the overheat protection temperature, the operating frequency is increased by about 4 to 10 Hz every 60 seconds until the normal operation condition resumes.

If the temperature of the compressor exceeds the overheat protection temperature (120 sec. : outdoor temperature ≥ 40°C, 60sec. : outdoor temperature < 40°C) at minimum operating frequency, the compressor stops operating and then restarts after about 180 seconds, and the above mentioned control is repeated.

5. Peak control

If the current flowing in the heat pump exceeds the peak control current (see the table below), the operation frequency is decreased until the current value drops below the peak control current regardless of the frequency control demand issued from the indoor unit based on the room temperature.

Mode	Peak Control Current(A)			
	Cooling		Heating	
Outdoor Air Temp.	<104°F (<40°C)	≥104°F (≥40°C)	<63°F (<17°C)	≥63°F (≥17°C)
AE-X3M24CU	13.8	12.9	13.8	12.8

6. Outdoor unit fan delay control

The compressor stops immediately after cooling or dehumidifying or heating operation is shut down, but the outdoor unit fan continues operation for 50 seconds.

7. Defrosting

7.1 Reverse defrosting

The defrost operation starts when the compressor operating time exceeds 10 minutes during heating operation, as shown below, and the outside air temperature and the outdoor unit heat exchanger temperature meet certain conditions. When the defrost operation starts, the indoor unit fan stops. The defrost operation stops when the outdoor unit heat exchanger temperature rises to about 8°C or higher or the defrosting time exceeds 10 minutes.

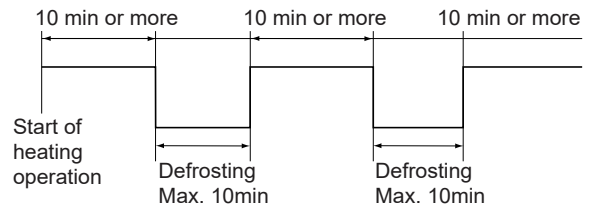

8. Self-diagnostic malfunction code display of Outdoor unit

If a malfunction occurs, LED1 on the outdoor unit flashes in 0.2-second intervals as shown below.

(Example) Compressor high temperature abnormality

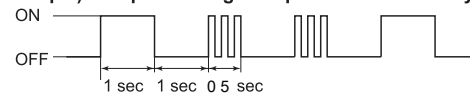

When reading the result of self-diagnosis, you shall combine it with indoor unit indication in order to get a correct conclusion.

For details, please refer to the troubleshooting section.

9. Mis-Wiring Check

“Mis-wiring check” is conducted by detecting the indoor heat exchanger temp. For example, when the expansion valve for only room A is open, and the wiring is correct, the indoor heat exchanger temp for room A will reduce. If the wiring is incorrect, the indoor heat exchanger temp for a different room will reduce.

10. Pump Down Switch

When the PUMP DOWN SWITCH (SW1) is pressed for 5 seconds or more, the total A/C system will start its PUMP DOWN automatically and the compressor frequency will be 40 Hz.

[3] PAM Circuit

1. PAM (Pulse Amplitude Modulation)

The PAM circuit varies the compressor drive voltage. The IGBT shown in the block diagram charges the energy (electromotive force) generated by the reactor to the electrolytic capacitor for the inverter by turning ON and OFF.

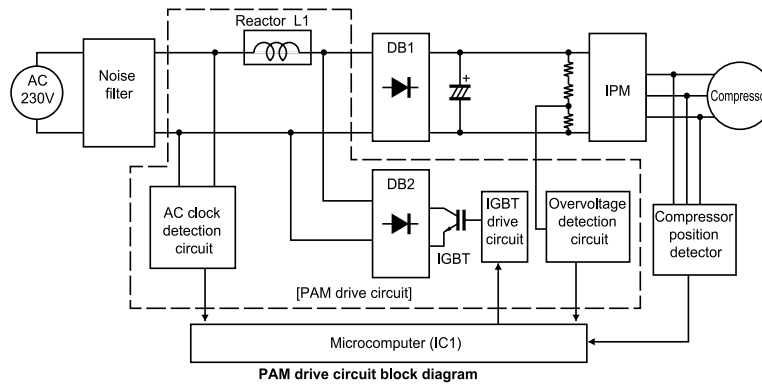

When the IGBT is ON, an electric current flows to the IGBT via the reactor (L1) and diode bridge (DB2). When the IGBT turns OFF, the energy stored while the IGBT was ON is charged to the voltage capacitor via the diode bridge (DB1). As such, by varying the ON/OFF duty of the IGBT, the output voltage is varied.

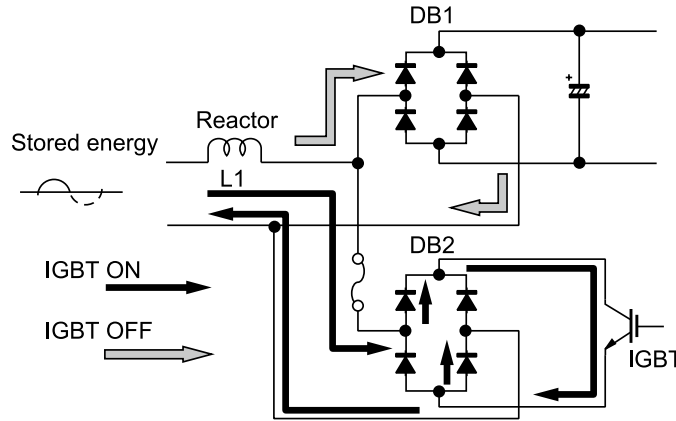

2. High power factor control circuit

This circuit brings the operating current waveform closer to the waveform of commercial power supply voltage to maintain a high power factor. Because of the capacitor input, when the PAM circuit is OFF, the phase of the current waveform deviates from the voltage waveform as shown below. To prevent this deviation, a current is supplied during the periods indicated by "t₁" in the diagram. To determine the length of period to supply a current, the zero-cross timing of the AC input voltage is input to the microcomputer via the clock circuit. The power source frequency is also determined at the same time. The IGBT turns ON after the time length determined by the zero-cross point to supply a current to the IGBT via the reactor. This brings the current waveform closer to the voltage waveform in phase. As described above, the ON/OFF operation of the IGBT controls the increase/decrease of the compressor power supply voltage (DC voltage) to improve the compressor efficiency and maintain a high power factor by keeping the current phase closer to that of the supply voltage.

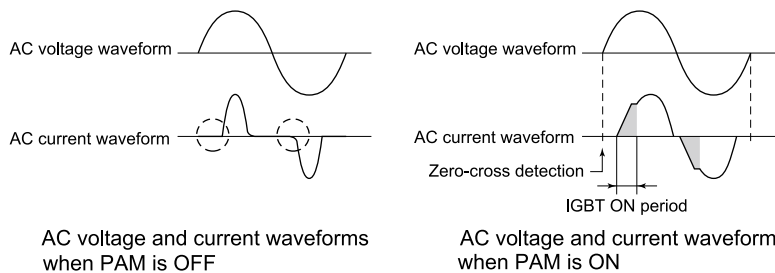

1) Detailed explanation of PAM drive circuit sequence

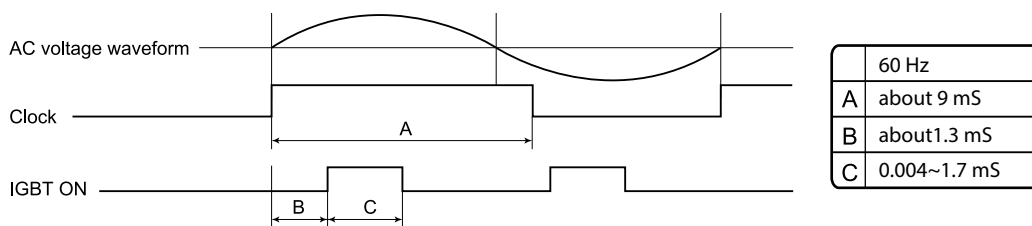

2) AC clock (zero-cross) judgment

- The clock circuit determines the time from one rising point of the clock waveform to the next rising point. The detected clock waveform is used to judge the power source frequency (60Hz).
- The zero-cross of the AC voltage is judged as the rising of the clock waveform, as shown in the diagram above.

3) IGBT ON start time (delay time B)

- Based on the zero-cross of the AC voltage, the IGBT turns ON after a delay time set according to the power source frequency.

4) IGBT ON time (C)

- After the above delay time, the IGBT turns ON to supply a current to the reactor.
- The ON time of the IGBT determines the amount of energy (level of DC voltage rise) supplied to the reactor. DC voltage level in each operation mode (varies depending on external load conditions)
 - Cooling operation --- 220 to 290 V
 - Heating operation --- 220 to 290 V

3.PAM protection circuit

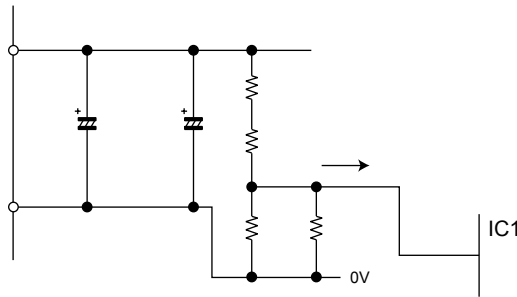

To prevent excessive voltage of PAM output from damaging the IPM and electrolytic capacitor as well as the control printed wiring board (PWB), this circuit monitors the PAM output voltage and turns off the PAM control signal and PAM drive immediately when an abnormal voltage output is generated. At the same time, it shuts off the compressor operation.

The protection voltage level is as follows.

Details of troubleshooting procedure for PAM

1) PAM shutdown due to error

- (1) When the DC voltage detection circuit sends a signal exceeding the specified voltage to the microcomputer DC voltage of 400 V or higher (detection circuit input voltage of about 9.2 V or higher)
 - When an error is detected
 - PAM IGBT turns OFF.
 - Compressor turns OFF.
 - All units shut down completely when the error occurs four times.
- (2) When the outdoor unit clock waveform differs from the specified value immediately before the PAM IGBT turns ON
 - When there is no clock waveform input
 - When a clock signal of other than specified power source frequency (60Hz) is input
 - When 14-1 error is detected
 - PAM IGBT does not turn ON.
 - Compressor turns OFF.
 - All units shut down completely when the error occurs four times.

2) PAM error indication

In case of error "(1)"

- An error signal is sent to the indoor unit as soon as an error is generated.
 - Malfunction No. 14-0 is indicated when the error code is called out by the indoor unit's self-diagnosis function.
- The LED on the outdoor unit flashes 14 times when an error is generated.
 - The LED continues flashing in the 14-time cycle even after the compressor stops operating.
 - The LED turns off (data is deleted from the memory) when the outdoor unit power is turned off.

In case of error "(2)"

- An error signal is sent to the indoor unit as soon as an error is judged.
 - Malfunction No. 14-1 is indicated when the error code is called out by the indoor unit's self-diagnosis function.
- The LED on the outdoor unit flashes 14 times when an error is judged.
 - The LED continues flashing in the 14-time cycle even after the compressor stops operating.
 - The LED turns off (data is deleted from the memory) when the outdoor unit power is turned off.
- Check items
 - Clock circuit check
 - PAM IGBT check

[4] IPM Drive Circuit

The IPM is used for compressor drive. The power supply for the IPM drive, the shunt resistance for over current detection, etc., are provided outside the IPM (control PWB).

1. IPM drive power supply circuit

The power supply for the upper-phase IGBT (HU, HV, HW) drive employs a bootstrap system, and provides power to the upper-phase IC. The 15-V power supply for the lower-phase IC is provided by the control printed wiring board (PWB).

1.1. Brief explanation of bootstrap system (single power drive system)

To supply power to the upper-phase IC, the microcomputer (IC1) turns ON the lower-phase IGBT (LU, LV, LW).

This results in a charging current that flows to the electrolytic capacitor of each upper-phase IC input and charges the bootstrap capacitor with a 15V current.

The power supply for the subsequent stages is charged while the lower-phase IGBT is ON in ordinary compressor drive control.

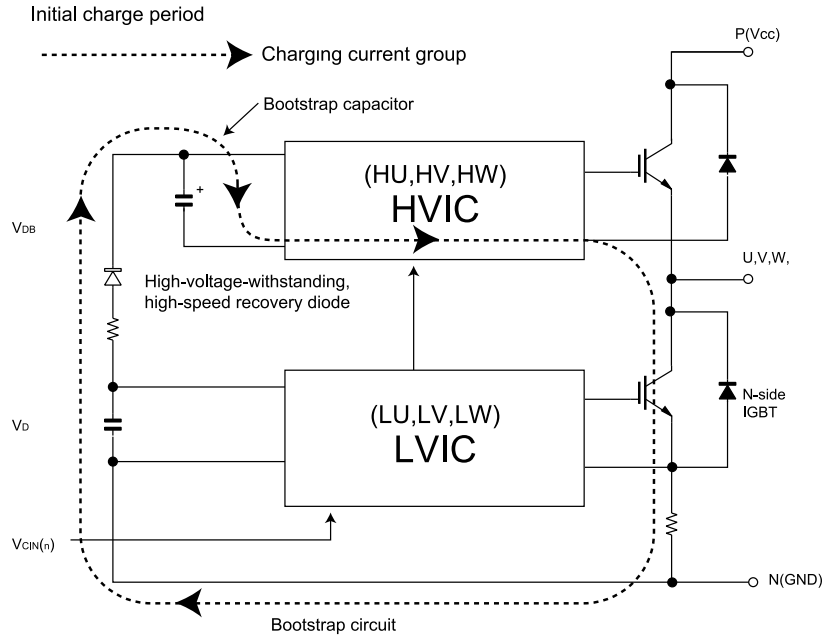

1.2 DC over current detection circuit

When a current of about 20 A or higher flows through the shunt resistance on the control printed wiring board (PWB), the voltage at this resistance is input to IPM CIN pin (15). Then, the gate voltage of the lower-phase IGBT (LU, LV, LW) inside the IPM turns OFF to cut off the over current. At the same time, an L output of more than 20μs is generated from IPM from pin (14), and this results in an L input to over current detection input pin (45) of the microcomputer (IC1) and turns OFF the PWM signal output (IC1 pins (37) through (39) and pins (42) through (44)) to the IGBT gate.

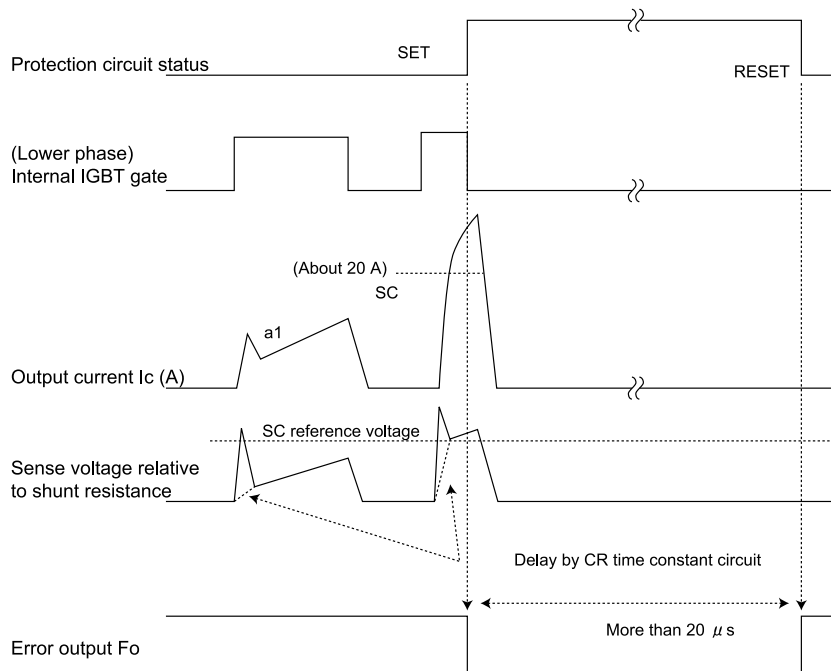

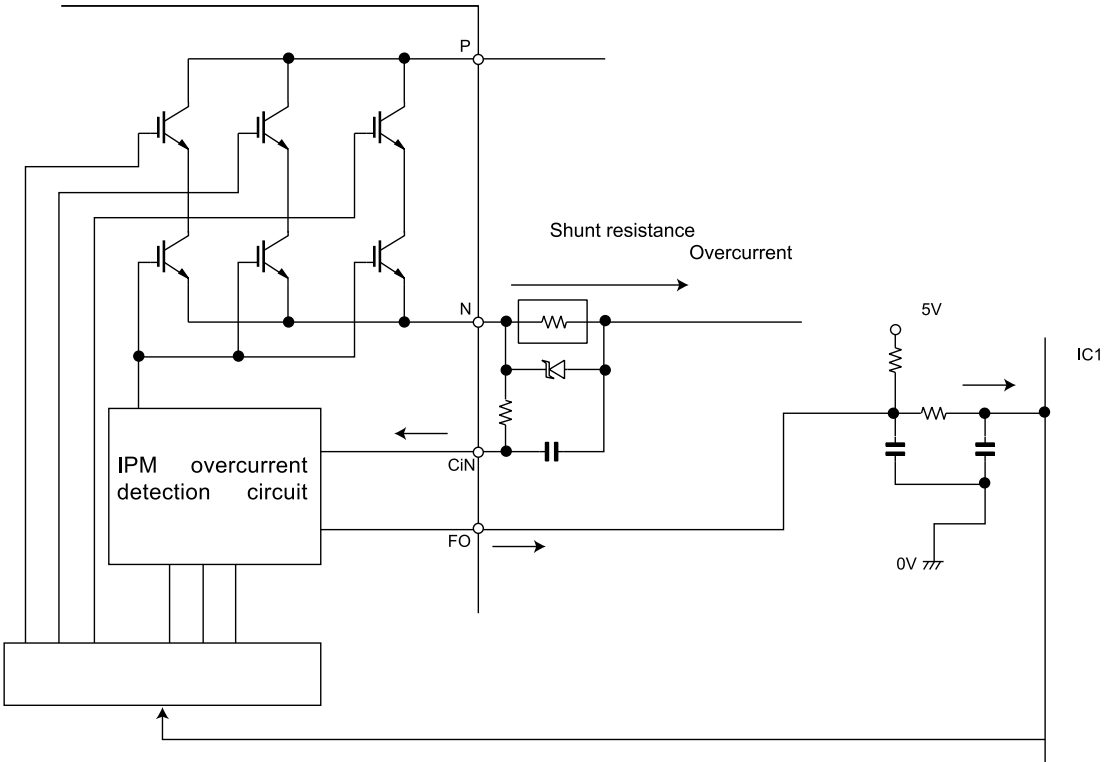

CHAPTER 4. FUNCTION AND OPERATION OF PROTECTIVE PROCEDURES

[1] PROTECTION DEVICE FUNCTIONS AND OPERATIONS

* These models have following thermistors

INDOOR UNIT	OUTDOOR UNIT
TH1, TH2, TH3	TH1, TH2, TH3, TH4, TH7, TH8, TH9, TH10

The errors for the thermistors that are not mentioned above are irrelevant.

These indoor units don't have power relay.

Function		Operation				Self-diagnosis result display	
		Description	Detection period	Reset condition	Indoor unit error display	Indoor unit	Outdoor unit
1	Indoor unit fan lock	Operation stops if there is no input of rotation pulse signal from indoor unit fan motor for 1 minute.	When indoor unit fan is in operation	Operation OFF or ON	☆ 2	Yes	None
	Indoor unit fan rotation speed error	Operation stops if rotation pulse signal from indoor unit fan indicates abnormally low speed (about 300 rpm or slower).	When indoor unit fan is in operation	Operation OFF or ON	☆ 2	Yes	None
2	Outdoor unit heat exchanger overheat shutdown	Operation frequency lowers if outdoor unit heat exchanger temperature exceeds about 55°C during cooling operation. Compressor stops if outdoor unit heat exchanger temperature exceeds about 55°C for 120 seconds at minimum frequency.	When in cooling or dehumidifying operation	Automatic reset after safety period (180 sec).	None	None	Yes
3	Compressor discharge overheat shutdown	Operating frequency lowers if temperature of compressor discharge thermistor (TH1) falls below about 110°C. Compressor stops if temperature of compressor discharge thermistor (TH1) remains at about 110°C (for 120 seconds in cooling operation, or 60 seconds in heating operation) at minimum frequency.	When compressor is in operation	Automatic reset after safety period (180 sec).	None	None	Yes
4	Dehumidifying operation temporary stop	Compressor stops if outside air temperature thermistor is lower than about 16°C during dehumidifying operation.	When in dehumidifying operation	Automatic reset when outside air temperature rises above 16°C.	None	None	Yes
5	DC over current error	Compressor stops if DC current of about 16 A or higher flows in IPM.	When compressor is in operation	Operation OFF or ON	Yes ☆ 3	Yes	Yes
6	AC over current error	Operating frequency lowers if outdoor AC current exceeds peak control current value. Compressor stops if compressor AC current exceeds peak control current value at minimum frequency.	When compressor is in operation	Operation OFF or ON	Yes ☆ 1	Yes	Yes
7	AC over current error in compressor OFF status	Indoor and outdoor units stop if outdoor AC current exceeds about 3 A while compressor is in non-operation status.	When compressor is in non-operation	Replacement of defective parts such as IPM	Yes ☆ 2	Yes	Yes
8	AC maximum current error	Compressor stops if outdoor AC current exceeds 17 A.	When compressor is in operation	Operation OFF or ON	Yes ☆ 2	Yes	Yes
9	AC current deficiency error	Compressor stops if operating frequency is 50 Hz or higher and compressor AC current is about 2.0 A or lower.	When compressor is in operation	Operation OFF or ON	Yes ☆ 1	Yes	Yes
10	Thermistor installation error or 4-way valve error	Compressor stops if high and low values of temperatures detected by outdoor unit heat exchanger thermistor (TH2) and 2-way valve thermistor (TH5) do not match operating cycle.	3 minutes after compressor startup	Operation OFF or ON	Yes ☆ 1	Yes	Yes
11	Compressor high temperature error	Compressor stops if compressor discharge thermistor (TH1) exceeds about 114°C, or if there is short-circuit in TH1.	When in operation	Operation OFF or ON	Yes ☆ 1	Yes	Yes

Function		Operation				Self-diagnosis result display	
		Description	Detection period	Reset condition	Indoor unit error display	Indoor unit	Outdoor unit
12	Outdoor unit heat exchanger thermistor short-circuit error	Compressor stops if there is shortcircuit in outdoor unit heat exchanger thermistor (TH2).	At compressor startup	Operation OFF or ON	Yes ☆ 1	Yes	Yes
13	Outdoor unit outside air temperature thermistor short-circuit error	Compressor stops if there is shortcircuit in outdoor unit outside air temperature thermistor (TH3).	At compressor startup	Operation OFF or ON	Yes ☆ 1	Yes	Yes
14	Outdoor unit suction thermistor short-circuit error	Compressor stops if there is shortcircuit in outdoor unit suction thermistor (TH4).	At compressor startup	Operation OFF or ON	Yes ☆ 1	Yes	Yes
15	Outdoor unit gas pipe thermistor short-circuit error	Compressor stops if there is shortcircuit in Outdoor unit gas pipe thermistor.	At compressor startup	Operation OFF or ON	Yes ☆ 1	Yes	Yes
16	Outdoor unit heat exchanger thermistor open-circuit error	Compressor stops if there is opencircuit in outdoor unit heat exchanger thermistor (TH2).	At compressor startup	Operation OFF or ON	Yes ☆ 1	Yes	Yes
17	Outdoor unit outside air temperature thermistor open-circuit error	Compressor stops if there is opencircuit in outdoor unit outside air temperature thermistor (TH3).	At compressor startup	Operation OFF or ON	Yes ☆ 1	Yes	Yes
18	Outdoor unit suction thermistor open-circuit error	Compressor stops if there is opencircuit in outdoor unit suction thermistor (TH4).	At compressor startup	Operation OFF or ON	Yes ☆ 1	Yes	Yes
19	Outdoor unit gas pipe thermistor open-circuit error	Compressor stops if there is opencircuit in Outdoor unit gas pipe thermistor.	At compressor startup	Operation OFF or ON	Yes ☆ 1	Yes	Yes
20	Outdoor unit discharge thermistor open-circuit error	Compressor stops if there is opencircuit in outdoor unit discharge thermistor (TH1).	At compressor startup	Operation OFF or ON	Yes ☆ 1	Yes	Yes
21	Serial signal error	Compressor stops if outdoor unit cannot receive serial signal from indoor unit for 30 seconds.	When in operation	Reset after reception of serial signal	None	None	None
22	Compressor startup error	Compressor stops if compressor fails to start up.	At compressor startup	Operation OFF or ON	Yes ☆ 3	Yes	Yes
23	Outdoor unit DC fan error	Operation stops if there is no input of rotation pulse signal from outdoor unit fan motor for 30 seconds.	When outdoor unit fan is in operation	Operation OFF or ON	Yes ☆ 1	Yes	Yes
24	PAM over voltage error	Compressor stops if DC voltage is 400 V or higher.	When in operation	Operation OFF or ON	Yes ☆ 1	Yes	Yes
25	PAM clock error	When power source frequency cannot be determined (at startup), or when power source clock cannot be detected for 1 continuous second (at startup).	At compressor startup, when in operation	Operation OFF or ON	Yes ☆ 1	Yes	Yes
26	Outdoor unit thermal fuse blown in the Terminal board	Serial signal is lost. As a result,compressor stops if outdoor unit cannot receive serial signal from indoor unit for 30 seconds.	When in operation	Reset after reception of serial signal	None	None	None
27	Solenoid valve error	Compressor stops if solenoid valve thermistor(TH10) cannot detect the temperature change by operating solenoid valve.	When in heating operation	Operation OFF or ON	Yes ☆ 2	Yes	Yes

☆ 1—The outdoor unit restarts four times before the indoor unit error is displayed (complete shutdown).

☆ 2—A single error judgment results in the display of the indoor unit error (complete shutdown).

☆ 3—The outdoor unit restarts eight times before the indoor unit error is displayed (complete shutdown).

[2] HEAT PUMP OPERATION IN THERMISTOR ERROR

* These models have following thermistors

INDOOR UNIT	OUTDOOR UNIT
TH1, TH2, TH3	TH1, TH2, TH3, TH4, TH7, TH8, TH9, TH10

The errors for the thermistors that are not mentioned above are irrelevant.

These indoor units don't have power relay.

1. Indoor unit

Item	Mode	Control operation	When resistance is low (temperature judged higher than actual)	Short-circuit	When resistance is high (temperature judged lower than actual)	Open-circuit
Room temperature thermistor (TH1)	Auto	Operation mode judgment	Cooling mode is activated even if room temperature is low.	Cooling mode is activated in most cases.	Heating mode is activated even if room temperature is high.	Heating mode is always activated.
	Cooling	Frequency control	Room becomes too cold.	Air to air heat pump operates in full power even after the room temp. reaches to the set temp.	Room does not become cool.	Compressor does not operate.
	Dehumidifying	Room temperature memory Frequency control	Normal operation.	Room temperature is stored in memory as 31.0°C, and compressor does not stop.	Normal operation.	Room temperature is stored in memory as 18.5°C, and compressor does not operate.
	Heating	Frequency control	Room does not become warm.	Hot keep status results immediately after operation starts. Frequency does not increase above 30 Hz (40 Hz).	Room becomes too warm.	Heat pump operates in full power even after the room temp. reaches to the set temp.
Heat exchanger thermistor (TH2)	Cooling Dehumidifying	Freeze prevention	Indoor unit evaporator may freeze.	Indoor unit evaporator may freeze.	Compressor stops occasionally.	Compressor does not operate.
	Cooling Dehumidifying	Freeze prevention	Indoor unit liquid pipe may freeze.	Indoor unit liquid pipe may freeze.	Compressor stops occasionally.	Compressor does not operate.
	Heating	Cold air prevention Cold	Cold air prevention deactivates too soon and cold air discharges.	Compressor operates at low speed or stops, and frequency does not increase.	Cold air prevention deactivates too slow.	Cold air prevention does not deactivate, and indoor unit fan does not rotate.
Liquid pipe thermistor (TH3)	Cooling Dehumidifying	Freeze prevention	Indoor unit evaporator may freeze.	Indoor unit evaporator may freeze.	Compressor stops occasionally.	Compressor does not operate.

2. Outdoor unit

Item	Mode	Control operation	When resistance is low (temperature judged higher than actual)	Short-circuit	When resistance is high (temperature judged lower than actual)	Open-circuit
Compressor discharge thermistor (TH1)	Cooling Dehumidifying Heating	Expansion valve control and compressor protection	Compressor operates, but room does not become cool or warm (expansion valve is open).	Compressor high temperature error indication.	Layer short-circuit or open-circuit may result in compressor in normal operation.	Outdoor unit thermistor open-circuit error indication.
Heat exchanger thermistor (TH2)	Cooling Dehumidifying	Outdoor unit heat exchanger overheat prevention	Compressor operates at low speed or stops.	Outdoor unit thermistor short-circuit error indication.	Normal operation.	Outdoor unit thermistor open-circuit error indication.
	Heating	Expansion valve control Defrosting	Defrosting operation is not activated as needed, and frost accumulates on outdoor unit (expansion valve is closed).	Outdoor unit thermistor short-circuit error indication.	Defrosting operation is activated unnecessarily, and room does not become warm (expansion valve is open).	Outdoor unit thermistor open-circuit error indication.

Item	Mode	Control operation	When resistance is low (temperature judged higher than actual)	Short-circuit	When resistance is high (temperature judged lower than actual)	Open-circuit
Outside air temperature thermistor (TH3)	Auto	Operation mode judgment	Cooling mode is activated even if room temperature is low.	Outdoor unit thermistor short-circuit error indication.	Heating mode is activated even if room temperature is high.	Outdoor unit thermistor open-circuit error indication.
	Cooling Dehumidifying	Operation not affected	Normal operation.	Outdoor unit thermistor short-circuit error indication.	Normal operation.	Outdoor unit thermistor open-circuit error indication.
	Heating	Rating control Defrosting	Defrosting operation is activated unnecessarily.	Outdoor unit thermistor short-circuit error indication.	Defrosting operation is not activated, and frost accumulates on outdoor unit.	Outdoor unit thermistor open-circuit error indication.
Suction pipe thermistor (TH4)	Cooling Dehumidifying	Operation not affected	Normal operation.	Outdoor unit thermistor short-circuit error indication.	Normal operation.	Outdoor unit thermistor open-circuit error indication.
	Heating	Expansion valve control	Compressor operates, but room does not become warm (expansion valve is open).	Outdoor unit thermistor short-circuit error indication.	Frost accumulates on expansion valve outlet section, and room does not become warm (expansion valve is closed).	Outdoor unit thermistor open-circuit error indication.
Outdoor unit gas pipe thermistor (TH7, TH8, TH9)	Cooling Dehumidifying	Expansion valve control	Compressor operates, but room does not become cool (expansion valve is open).	Outdoor unit thermistor short-circuit error indication.	Frost accumulates on indoor unit evaporator and room does not become cool (expansion valve is closed).	Outdoor unit thermistor open-circuit error indication.
	Heating	Operation not affected	Normal operation.	Outdoor unit thermistor short-circuit error indication.	Normal operation.	Outdoor unit thermistor open-circuit error indication.
Solenoid valve thermistor (TH10)	Cooling Dehumidifying	Operation not affected	Normal operation.	Outdoor unit thermistor solenoid valve error indication.	Normal operation.	Outdoor unit thermistor solenoid valve error indication.
	Heating	Solenoid valve control Defrosting	Defrosting operation is activated unnecessarily.	Outdoor unit thermistor solenoid valve error indication.	Defrosting operation is not activated, and frost accumulates on outdoor unit.	Outdoor unit thermistor solenoid valve error indication.

[3] THERMISTOR TEMPERATURE CHARACTERISTICS

1. Indoor unit

To measure the resistance, first remove the connector from the board.

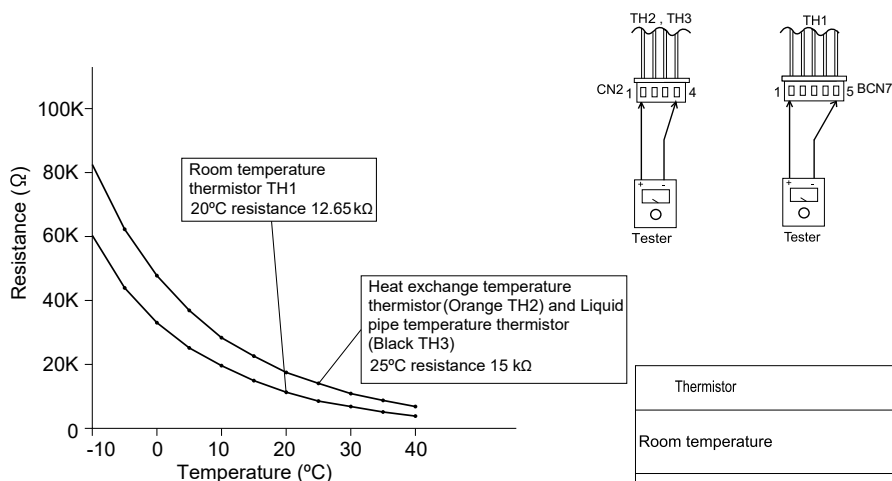

Thermistor	Symbol	Connector	Color
Room temperature	TH1 (BCN7)	① - ⑤	-
Heat exchange temperature	TH2 (CN2)	① - ②	Orange
Liquid pipe temperature	TH3 (CN2)	③ - ④	Black

2. Outdoor unit

To measure the resistance, first remove the connector from the board.

Temperature properties of outdoor thermistors

- TH1 : Compressor thermistor (CN8A ① - ②)
- TH2 : Heat exchanger pipe thermistor (CN8A ③ - ④)
- TH3 : Outdoor temp. thermistor (CN8A ⑤ - ⑥)
- TH4 : Suction thermistor (CN8A ⑦ - ⑧)
- TH7 : Thermistor unit A (CN8B ① - ②)
- TH8 : Thermistor unit B (CN8B ③ - ④)
- TH9 : Thermistor unit C (CN8B ⑤ - ⑥)
- TH10 : Solenoid Valve (CN8B ⑦ - ⑧)

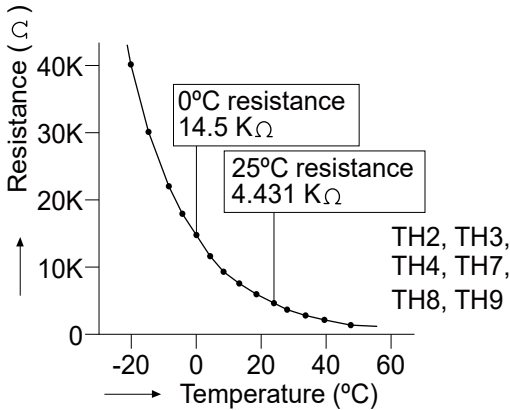
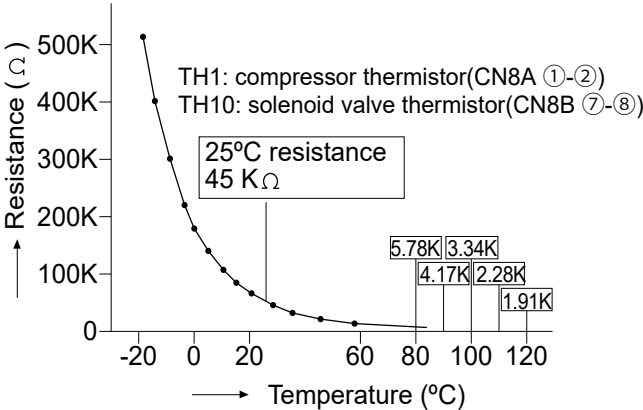
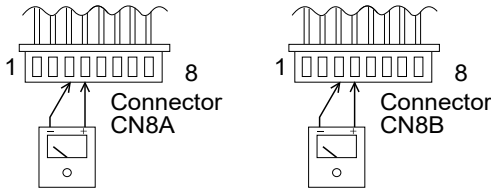

Thermistor	No.	Connector	Color	Connector pin
Compressor thermistor	TH1	CN8A	Red	No. 1 to 2
Heat exchanger pipe thermistor	TH2	CN8A	Orange	No. 3 to 4
Outdoor temp. thermistor	TH3	CN8A	Green	No. 5 to 6
Suction thermistor	TH4	CN8A	Black	No. 7 to 8
Thermistor unit A (suction)	TH7	CN8B	Blue	No. 1 to 2
Thermistor unit B (suction)	TH8	CN8B	White	No. 3 to 4
Thermistor unit C (suction)	TH9	CN8B	Brown	No. 5 to 6
Solenoid Valve thermistor	TH10	CN8B	Yellow	No. 7 to 8

[4] GENERAL TROUBLESHOOTING CHART**1.Indoor unit does not turn on**

Main cause	Inspection method	Normal value/condition	Remedy
Cracked PWB. (Cracked pattern)	Check visually.	There should be no cracking in PWB or pattern.	Replace PWB.
Open-circuit in FU1 (250 V, 3.15 A)	Check melting of FU1.	There should be no open-circuit.	Replace PWB.

2.Indoor unit fan does not operate

Main cause	Inspection method	Normal value/condition	Remedy
Open-circuit in heat exchanger thermistor (TH2) (in heating operation)	Measure thermistor resistance (dismount for check).	Refer to THERMISTOR TEMPERATURE CHARACTERISTICS-1	Replace thermistor.
		There should be no open-circuit or faulty contact.	Replace thermistor.
Disconnected heat exchanger thermistor (TH2) (in heating operation)	Inspect connector on PWB. Check thermistor installation condition.	Thermistor should not be disconnected.	Install correctly.

3.Indoor unit fan speed does not change

Main cause	Inspection method	Normal value/condition	Remedy
Remote control not designed to allow fan speed change.	Check operation mode.	Fan speed should change except during dehumidifying operation, ventilation, light dehumidifying operation, internally normal operation	Explain to user.

4.Remote control signal is not received

Main cause	Inspection method	Normal value/condition	Remedy
Batteries at end of service life.	Measure battery voltage.	2.5 V or higher (two batteries in series connection)	Install new batteries.
Batteries installed incorrectly.	Check battery direction.	As indicated on battery compartment.	Install batteries in indicated direction.
Lighting fixture is too close, or fluorescent lamp is burning out.	Turn off light and check.	Signal should be received when light is turned off.	Change light position or install new fluorescent lamp.

Main cause	Inspection method	Normal value/condition	Remedy
Use Sevick light (Hitachi).	Check if Sevick light (Hitachi) is used.	Signal may not be received sometimes due to effect of Sevick light.	Replace light or change position.
Operating position/angle are inappropriate.	Operate within range specified in manual.	Signal should be received within range specified in manual.	Explain appropriate handling to user.
Open-circuit or short-circuit in wiring of light receiving section.	Check if wires of light receiving section are caught.	Wires of light receiving section should not have any damage caused by pinching.	Replace wires of light receiving section.
Defective light receiving unit.	Check signal receiving circuit (measure voltage between terminals 5 and 9 of connector BCN8).	Tester indicator should move when signal is received.	Replace PWB.
Dew condensation on light receiving unit.	Check for water and rust.	Signal should be received within range specified in manual.	Take moisture-proof measure for lead wire outlet of light receiving section.

5.Louvers do not move

Main cause	Inspection method	Normal value/condition	Remedy
Caught in sliding section.	Operate to see if louvers are caught in place.	Louvers should operate smoothly.	Remove or correct catching section.
Disconnected connector	Inspect connectors.	Connectors or pins should not be disconnected.	Install correctly.
Contact of solder on PWB (connector section on PWB)	Check visually.	There should not be solder contact.	Correct contacting section.

6.There is noise in TV/radio

Main cause	Inspection method	Normal value/condition	Remedy
Grounding wires not connected properly.	Check grounding wire connections.	Grounding wires should be connected properly.	Connect grounding wires properly.
TV/radio is placed too close to outdoor unit.	Check distance between TV/radio and outdoor unit.	If TV/radio is placed too close, it may become affected by noise.	Move TV/radio away from outdoor unit.
Other than above.	Check for radio wave interference.		

7. Malfunction occurs

Main cause	Inspection method	Normal value/condition	Remedy
Malfunction caused by noise.	Check for radio wave interference.		

8.Compressor does not start

Main cause	Inspection method	Normal value/condition	Remedy
Erroneous inter-unit connection.	Check wiring between indoor and outdoor units.	Terminal board L1-L2: 230 VAC, 60 Hz Terminal board 2: serial signal	Correct wiring.
Damaged IPM.	Check IPM continuity.	-	Replace outdoor unit PWB.
Dried-up electrolytic capacitor.	Check electrolytic capacitor.	-	Replace outdoor unit PWB.
Blown outdoor unit fuse.	Check 20-A fuse.	Fuse should not be blown.	Replace fuse. Replace outdoor unit PWB.
Power supply voltage is too low.	Measure power supply voltage during startup.	230±10 VAC, 60 Hz	Make sure that power supply voltage is 180 V or higher.
Compressor lock.	Supply current and touch compressor cover(sound absorbing material) to check if operation starts.	Compressor should start normally.	Apply external impact to compressor. Replace compressor.

9.Operation stops after a few minutes and restarts, and this process repeats

Main cause	Inspection method	Normal value/condition	Remedy
Dried-up electrolytic capacitor.	Measure 290-VDC line voltage.	250 V or higher.	Replace outdoor unit PWB.
Layer short-circuit in expansion valve coil.	Measure resistance.	46±3Ω in each phase (at 20°C)	Replace coil.

CAUTION:

If fuse FU1/FU5 (outdoor unit control circuit board) is blown, be careful of charging voltage in inverter electrolytic capacitor C8,C9,C10.

To discharge stored electricity, unplug the power cord and connect the plug of a soldering iron (230VAC, 30W) between the positive and negative terminals of inverter electrolytic capacitor C8,C9,C10.

[5] MALFUNCTION (PARTS) CHECK METHOD

1.Procedure for determining defective outdoor unit IPM/compressor

The following flow chart shows a procedure for locating the cause of a malfunction when the compressor does not start up and a DC over current indication error occurs.

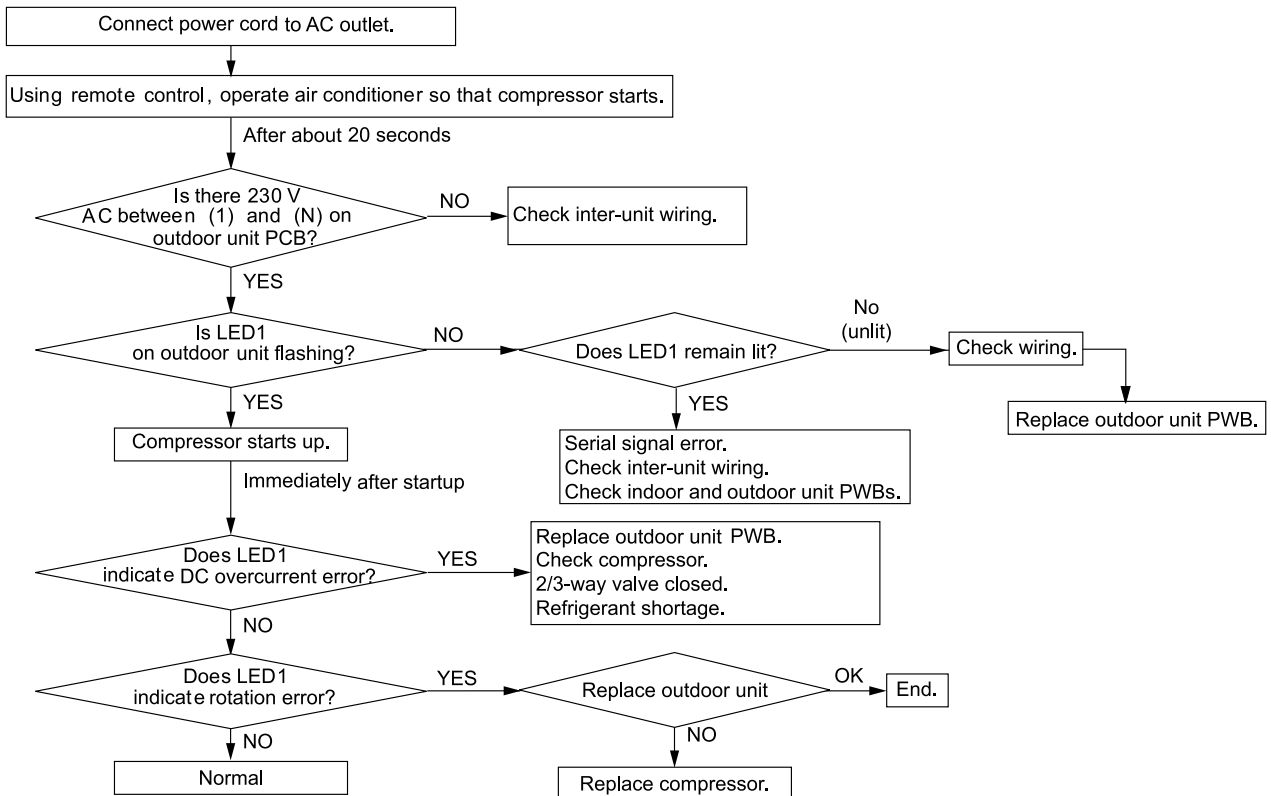

2.Diode bridge check method

Turn off the power and let the inverter electrolytic capacitor discharge completely. Then use a tester and check continuity. When using a digital tester, the (+) and (-) tester lead wires in the table must be reversed.

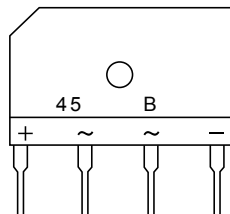
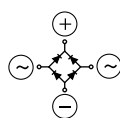

Needle-type tester		Normal resistance value
+	-	
+	-	∞ (several MΩ)
-	+	
-	-	
+	+	

Value in () is for digital tester.

3. Inverter electrolytic capacitor (C8,C9,C10) check method

Turn off the power, let the inverter electrolytic capacitor (C8,C9,C10) discharge completely, and remove the capacitor from the control printed circuit board (PWB). First, check the case for cracks, deformation and other damages. Then, using a needle-type tester, check continuity.

Determination of normal condition		
The tester needle should move on the scale and slowly returns to the original position. The tester needle should move in the same way when polarities are reversed. (When measurement is taken with the polarities reversed, the tester needle exceeds the scale range. Therefore, let the capacitor discharge before measurement.)		

4. IPM check method

Turn off the power, let the large capacity electrolytic capacitor (C8,C9,C10) discharge completely, and dismount the IPM. Then, using a tester, check leak current between C and E.

When using a digital tester, the (+) and (-) tester lead wires in the table must be reversed.

Needle-type tester		Normal resistance value
(-)	(+)	
P	N	∞ (several M Ω)
	U	
	V	
	W	

Needle-type tester		Normal resistance value
(-)	(+)	
U	N	∞ (several M Ω)
V		
W		

Values in () are for digital tester.

5. DC Over Current Error (6-0 error)

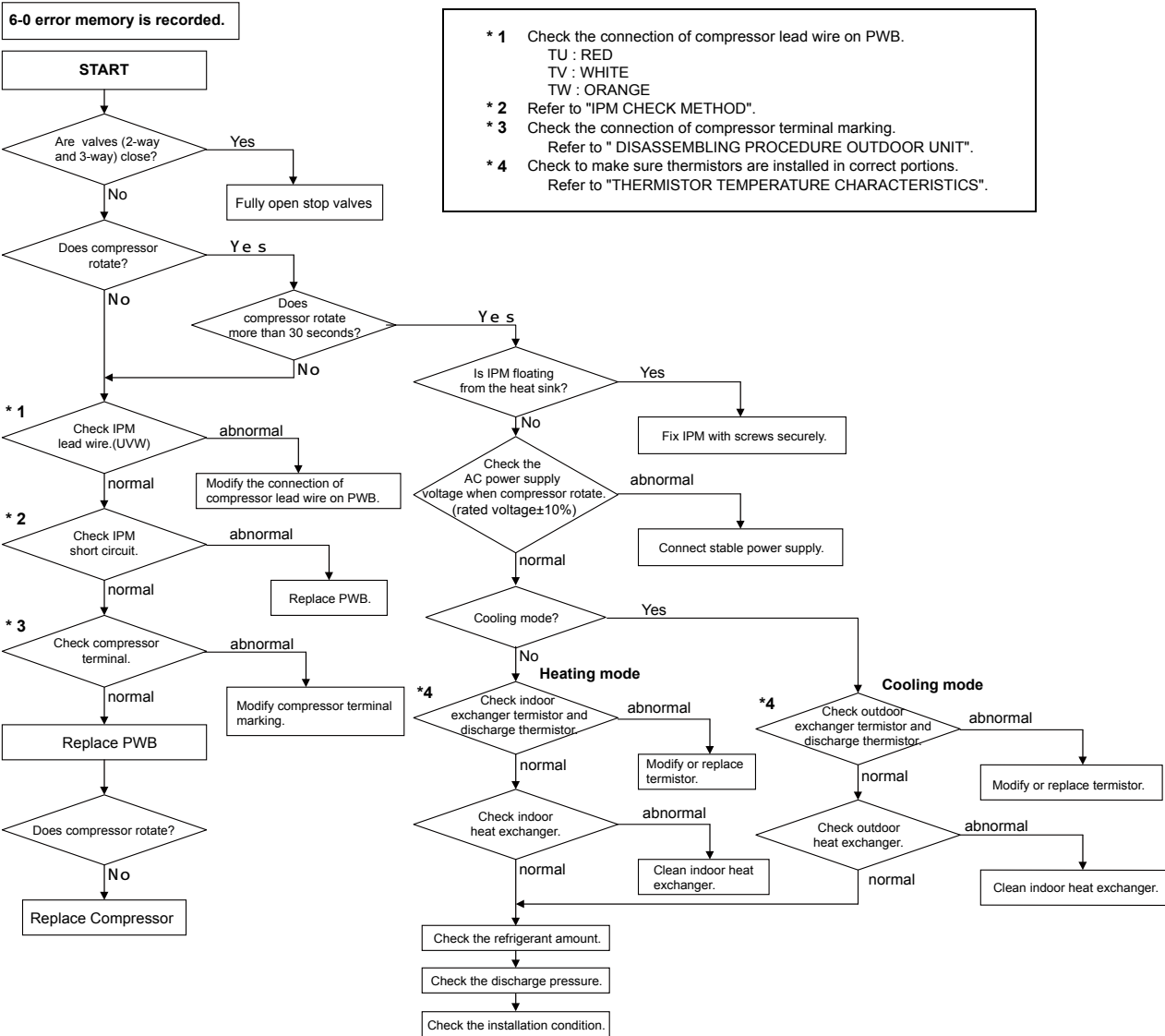

[6] OUTDOOR UNIT CHECK METHOD

After repairing the outdoor unit, conduct the following inspection procedures to make sure that it has been repaired completely. Then, operate the compressor for a final operation check.

1. Troubleshooting of outdoor unit electric components

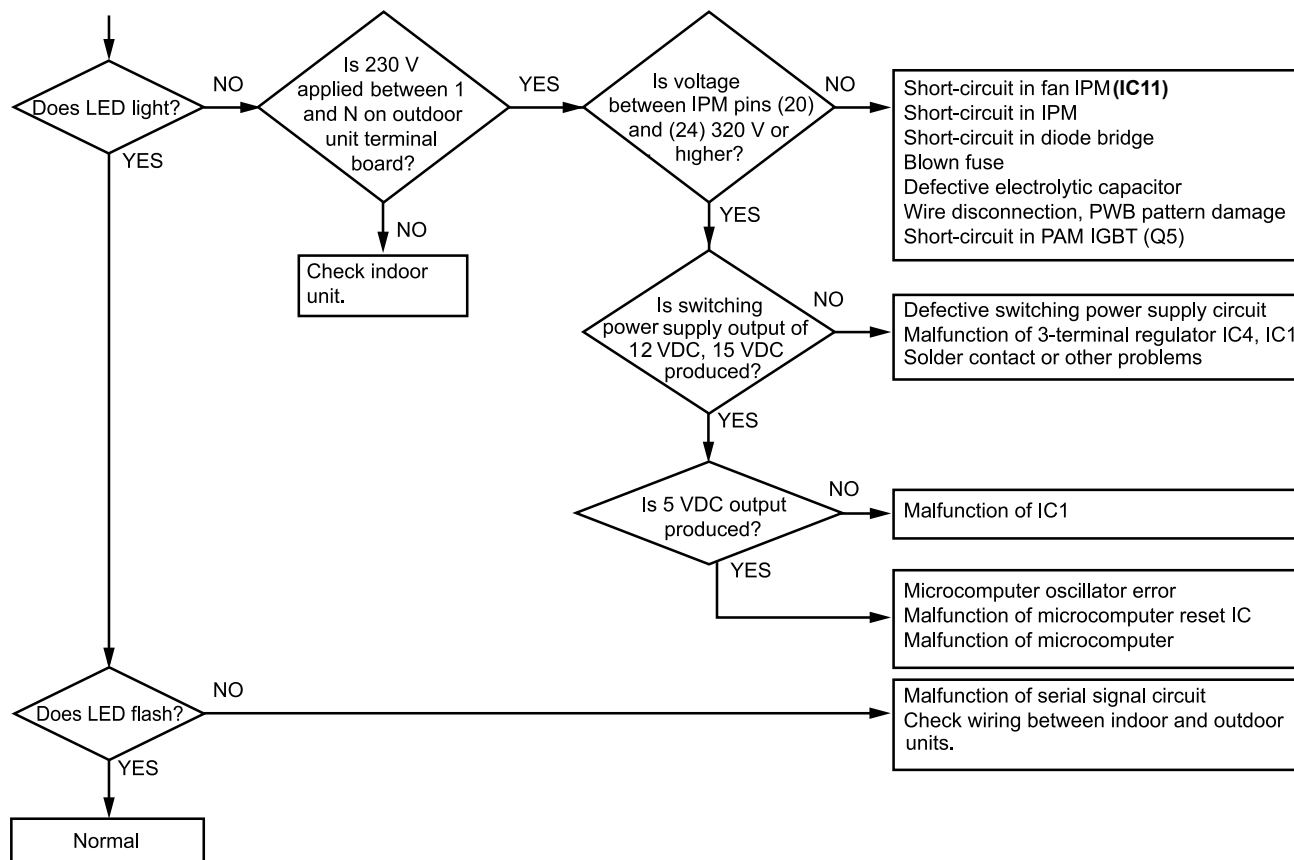

2. Caution in checking printed circuit boards (PWB)

2.1. Non-insulated control circuit

The GND terminals of the low-voltage circuits (control circuits for microcomputer and thermistors and drive circuits for expansion valve and relays) on the control printed circuit board (PWB) are connected to the compressor drive power supply (320-VDC negative terminal). Therefore, exercise utmost caution to prevent electric shock.

If a measuring instrument used for the test is grounded, its chassis (ground) has the same electric potential as the 0-V probe. Since non-insulated circuits have the following voltage potential difference from the ground, connection of the grounding wire results in a short-circuit between the 0-V line and the ground, thus allowing an excessive current to flow to the tester to cause damage.

If the sheaths of the thermistor lead wires or expansion valve lead wires inside the outdoor unit become damaged due to pinching by the front panel or other metal parts or contacting a pipe, a high voltage can flow and destroy the circuits. To prevent these problems, carefully conduct assembly work.

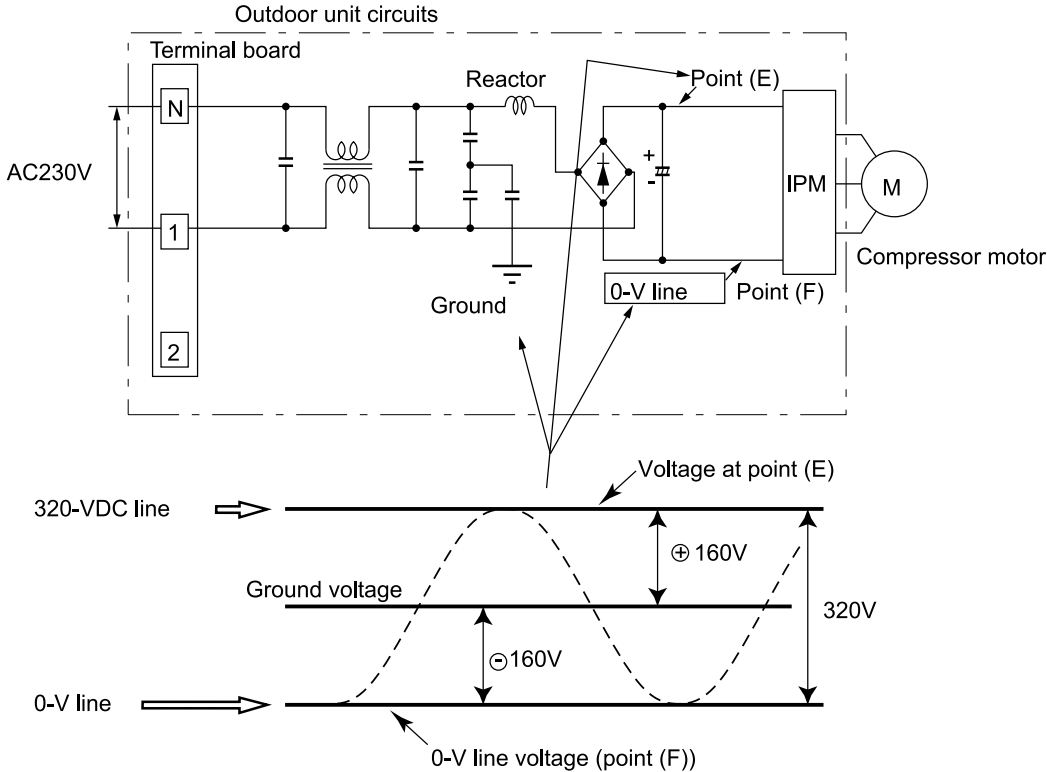

Reason

The oscilloscope (chassis ground) has the same electric potential as the 0-V probe. The entire electronic control section of the outdoor unit has a voltage potential difference from the ground as shown in the above diagram. When the oscilloscope is set up, the 0-V line and the ground voltage (ground) will be short-circuited, resulting in an excessive current flow to cause damage to the oscilloscope or indoor electric circuits.

[7] TROUBLESHOOTING GUIDE

1. Self-Diagnosis Function

1.1 Indoor unit

- At below situation, the operation lamp (Green), timer lamp (Orange) and WLAN lamp (Green) flash to indicate the information of malfunction.

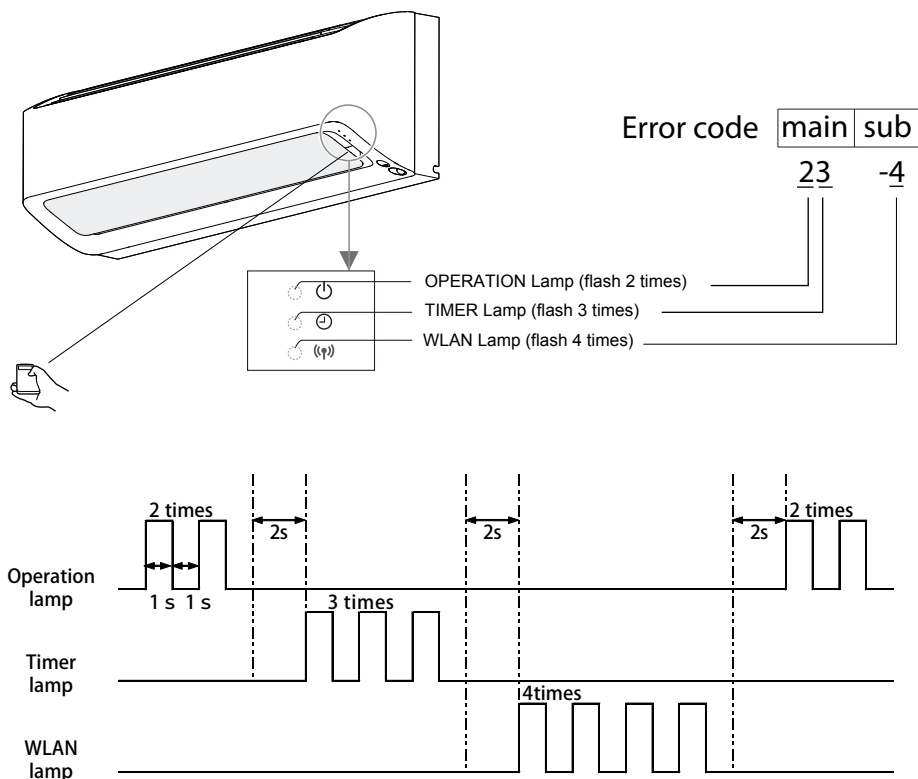

1) when the unit stops all operation by itself due to malfunction, the error will indicate.

2) Press the 'STOP' button on remote control by more than 5 times when unit is not operating,

"STOP"(Bip-) → "STOP"(Bip-) → "STOP"(Bip-) → "STOP"(Bip-) → "STOP"(Bip Bip Bip), the newest error will indicate.



3) Hold the  button on remote control for a while when unit is not operating, the error will indicate.

4) Hold down the ON/OFF button for over 5 seconds on the indoor unit when the indoor unit is not operating,

		Buzzer (Bip sound)	Indication on unit
Step 1	Hold down the ON/OFF button for over 5 seconds on the indoor unit when the indoor unit is not operating.	Bip (when hold the button) Bip Bip Bip (after 5 seconds)	Indicate the newest error information
Step 2	Hold down the ON/OFF button for over 5 seconds again.	Bip (when hold the button) Bip Bip (after 5 seconds)	Indicate the second newest error information
Step 3	Hold down the ON/OFF button for over 5 seconds again.	Bip (when hold the button) Bip Bip Bip (after 5 seconds)	Indicate the third newest error information
Step 4	Hold down the ON/OFF button for over 5 seconds again.	Bip (when hold the button) Bip Bip Bip Bip (after 5 seconds)	Indicate the fourth newest error information
Step 5	Hold down the ON/OFF button for over 10 seconds.	Bip (when hold the button) Bip- (after 10 seconds)	Delete the memory of below 4 error information.

• When service finished, make sure the error information is deleted, **that will benefit to distinguish new error and old error.**

• The indication on unit will stop,

- after indicate for 3 minutes (only at the situation of 2), 3).
- after indicate for 5 minutes (only at the situation of 4).
- unit received signal of operation start.
- unit received signal of operation stop.

1.2. Outdoor unit

- The self-diagnosis is indicated the error information by flashing LED1 on the outdoor unit.
- The self-diagnosis of outdoor unit is displayed for about 3-10 minutes. Then, the LED1 returns to normal display.

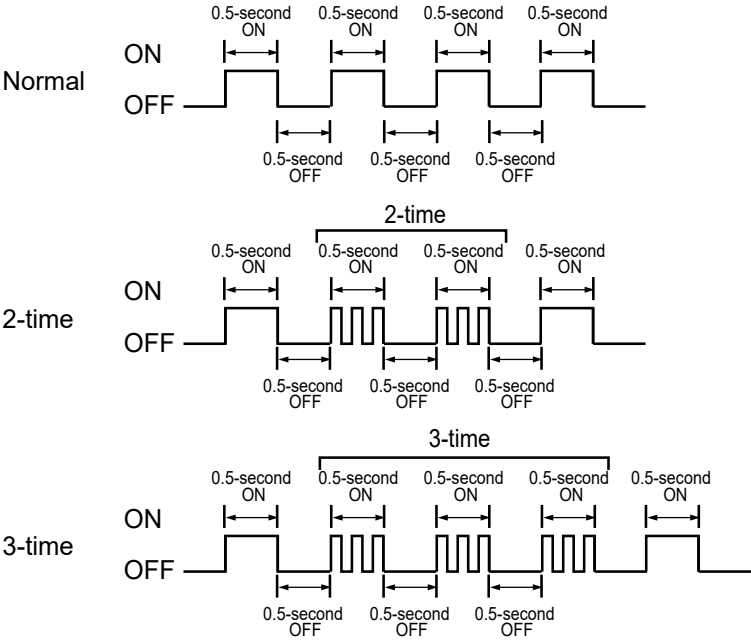
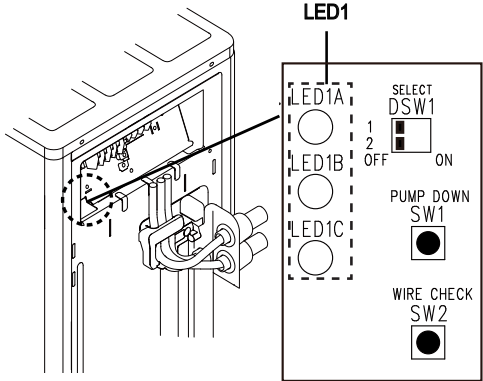

2. Self-Diagnosis Function

<Error code display on remote control >

Example: Error 23 -4.

STEP1

- To display the self-diagnosis, hold down the THERMOSTAT button ① for over 5 seconds on remote control when the indoor unit and remote control are off.
- The remote control will display "00".

STEP2

- Press the THERMOSTAT button ① and ②, remote control display will change from "00" to "31" step by step.
- Meanwhile, buzzer makes a short beep sound on every step.
- When it displays "23", the buzzer will make a long beep sound to remind you this error code "23" is main error code..

STEP3

- Press the FAN button ③ once, the remote control will display "-0".

STEP4

- then press the THERMOSTAT button ① and ②, remote control display will change from "-0" to "-7" step by step.
- Meanwhile, buzzer makes a short beep sound on every step.
- When it displays "-4", the buzzer will make a long beep sound to remind you this error code "4" is sub error code.

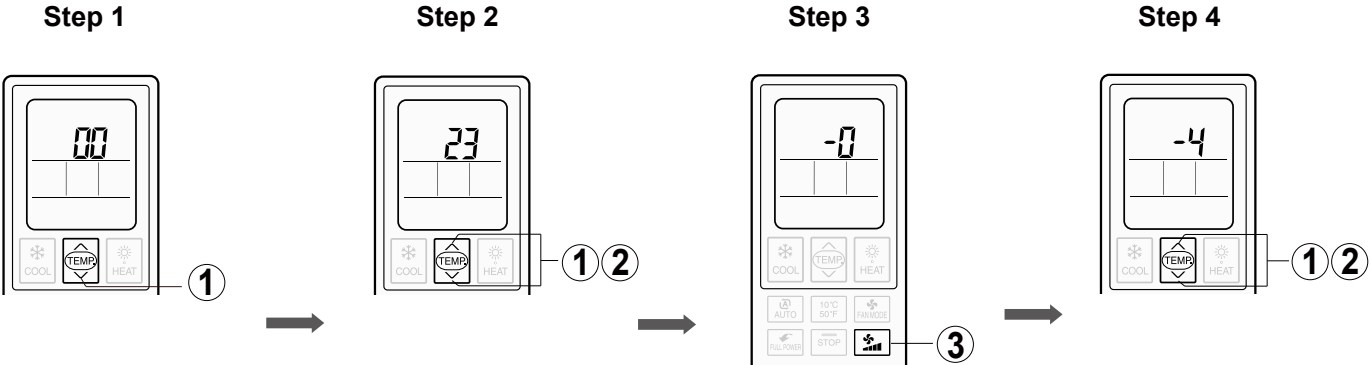

3.Chart for Reading Self-Diagnosis

Depending on the model, some errors may not occur.

Problem symptom	Outdoor unit indication (LED1)	Malfunction No.*		Content of diagnosis		Check point	Action
		Main	Sub	Main	Sub		
Normal condition	Normal blinking	0	0	Normal			
Indoor and outdoor units do not operate.	1-time	1	0	Outdoor unit thermistor short-circuit	Heat exchanger thermistor short circuit error	1) Measure the resistance of the outdoor unit thermistors. 2) Check the lead wire of the outdoor unit thermistor for torn sheath and short circuit. 3) No abnormality found in above inspections 1) and 2).	1) Replace the outdoor unit thermistor assembly. 2) Replace the outdoor unit thermistor assembly. 3) Replace the outdoor unit control PWB assembly.
			1		Outdoor temperature thermistor short circuit error		
			2		Suction thermistor short circuit error		
			3 (For multi zone system)		Gas pipe thermistor (for unit A,B,C) short circuit error	-	Replace the outdoor unit control PWB.
			3 (For single zone system)		2-way valve thermistor short circuit error		
			4		Heatsink thermistor error	1) Measure the resistance of the outdoor unit thermistors. 2) Check the lead wire of the outdoor unit thermistor for torn sheath and short circuit. 3) No abnormality found in above inspections 1) and 2).	1) Replace the outdoor unit thermistor assembly. 2) Replace the outdoor unit thermistor assembly. 3) Replace the outdoor unit control PWB assembly.
5	Discharge thermistor short-circuit error						
Indoor and outdoor units do not operate.	2-time	2	0	Cycle temperature	Compressor high temperature error	1) Check the outdoor unit air outlet for blockage.	1) Ensure unobstructed air flow from the outdoor unit air outlet.
					2) Check if the power supply voltage is AC 230V at full power.	2) Connect power supply of proper voltage.	
					3) Check the pipe connections for refrigerant leaks.	3) Charge the specified amount of refrigerant.	
					4) Measure resistance of the outdoor unit compressor thermistor.	4) Replace the outdoor unit compressor thermistor assembly.	
					5) Check the expansion valve for proper operation.	5) Replace the expansion valve coil, expansion valve or outdoor unit control PWB assembly.	

Problem symptom	Outdoor unit indication (LED1)	Malfunction No.*		Content of diagnosis		Check point	Action
		Main	Sub	Main	Sub		
Indoor unit operates. Outdoor unit does not operate temporarily	2-time	2	1	Cycle temperature	Compressor discharge overheat.	1) (Temporary stop for cycle protection)	-
			2		Outdoor unit heat exchanger overheat.		-
			3		Indoor unit heat exchanger overheat.		-
			4		IPM high temperature error	Measure resistance of the heat-sink thermistor.	-
			5		IPM high temperature error		1) Ensure unobstructed air flow from the outdoor unit air outlet. 2) Check the outdoor unit fan motor. 3) Replace the outdoor unit control PWB.
Indoor and outdoor units do not operate.							
Indoor unit operates. Outdoor unit does not operate temporarily.	3-time	3	0	Dry operation	Temporary stop due to dehumidifying operation	1) (Temporary stop for cycle protection).	-
				Heat operation (For multi zone system only)	-17°F(-27°C). AUTO OFF		Measure the resistance of outdoor temperature thermistor.
Indoor and outdoor units do not operate.	5-time	5	0	Outdoor unit thermistor open-circuit	Heat exchanger thermistor open circuit error	1) Check connector of outdoor unit thermistor for secure installation. 2) Measure resistance of outdoor thermistors. 3) Check the lead wires of thermistors on the outdoor unit control PWB for open-circuit. 4) No abnormality found in above inspections 1) through 3).	1) Correct the installation.
			1		Outdoor temperature thermistor open circuit error		2) Replace the outdoor unit thermistor assembly.
			2		Suction thermistor open circuit error		3) Replace the outdoor unit thermistor assembly.
			3 (For multi zone system only)		Gas pipe thermistor (for unit A,B,C) open circuit error.		
			3 (For single zone system)		2-way valve thermistor open circuit error.		4) Replace the outdoor unit control PWB assembly.
			4		Discharge thermistor open circuit error		
			5		Heat sink thermistor open circuit error		
Indoor and outdoor units do not operate.	6-time	6	0	Outdoor unit DC Current	DC over current error	-	Replace the outdoor unit IPM PWB assembly.
			1		IPM pin level error		
			2		Compressor rotation error		1) Correct the installation & Silicone grease application. 2) Replace the outdoor unit fan motor. 3) Replace the outdoor unit PWB assembly.
			3		Other factors		•Cycle error •Overheat judgment thermistor off •Filter and Heat Exchange dust clogging

Problem symptom	Outdoor unit indication (LED1)	Malfunction No.*		Content of diagnosis		Check point	Action
		Main	Sub	Main	Sub		
Indoor and outdoor units do not operate.	7-time	7	0	Outdoor unit AC Current	AC over current error	1) Check the outdoor unit air outlet for blockage.	1) Ensure unobstructed air flow from the outdoor unit air outlet.
						2) Check the outdoor unit fan for proper rotation.	2) Check the outdoor unit fan motor.
			1		AC current error when OFF	1) IPM continuity check.	1) Replace the outdoor IPM PWB.
			2		AC maximum current error	1) Check the outdoor unit air outlet for blockage.	1) Ensure unobstructed air flow from the outdoor unit air outlet.
						2) Check the outdoor unit fan for proper rotation.	2) Check the outdoor unit fan motor.
			3		AC current deficiency error	1) Check if there is an open-circuit in the secondary winding of the current transformer of the outdoor unit control PWB.	1) Replace the outdoor unit control PWB assembly.
2) Check if the refrigerant volume is abnormally low.	2) Charge the specified amount of refrigerant.						
3) Check if the refrigerant flows properly.	3) Correct refrigerant clogs. (Stop valve, pipe, expansion valve).						
Indoor and outdoor units do not operate.	8-time	8	0	Abnormal wire check	Abnormal wire check error	1) Check the expansion valve. 2) Are four expansion valves connected by mistake. 3) Check the wiring between units.	1) Replace the outdoor control board assembly. 2) Reattach 3) Check the wiring between units.

Problem symptom	Outdoor unit indication (LED1)	Malfunction No.*		Content of diagnosis		Check point	Action
		Main	Sub	Main	Sub		
Indoor and outdoor units do not operate.	9-time	9	0	Cycle temperature	Thermistor installation error or 4-way valve error.	1) Check the thermistor (heat exchanger) and (2-way valve) are installed in correct positions.	1) Correct the installation.
						2) Check resistance of thermistors (heat exchanger and 2-way valve).	2) Replace the outdoor unit thermistor assembly.
						3) Check the 4-way valve for proper operation.	3) Replace the 4-way valve.
						4) No abnormality found in above inspections (1), through(3).	4) Replace the outdoor unit control PWB assembly.
Indoor and outdoor units do not operate.			4		4 way valve error or Gas leak error.	1) Check the indoor/ outdoor heat exchanger thermistors are installed in correct positions.	1) Correct the installation.
						2) Check if the refrigerant volume is abnormally low.	2) Change the specified amount of refrigerant.
						3) Check the 4-way valve for proper operation.	3) Replace the 4-way valve.
			5		2-way valve and 3-way valve close error	1) Check the 2-way valve and 3-way valve.	1) Open the 2-way valve and 3-way valve.
						2) Check the thermistor (heat exchanger) are installed in correct positions. 3) Check the expansion valve operation.	2) Correct the installation. 3) Replace Expansion valve coil or Expansion valve or the outdoor unit control PWB assembly.
			6 (For multi zone system only)		Solenoid valve error	1) Check the thermistor (solenoid valve) is installed in correct position.	1) Correct the installation.
						2) Check resistance of thermistors(discharge and solenoid valve).	2) Replace the outdoor unit thermistor assembly.
						3) Check the solenoid valve for proper operation.	3) Replace the solenoid valve.
4) No abnormality found in above inspections 1), through3).	4) Replace the outdoor unit control PWB assembly.						
Indoor and outdoor units do not operate.	10-time	10	0 (For single zone system only)	EEPROM error	EEPROM (outdoor) data error	-	1) Replace the outdoor unit control PWB assembly.
			1 (For single zone system only)		EEPROM (outdoor) data error		
			2		CPU(outdoor) RAM data error		
			3		CPU error		
			4	EEPROM Mutual memory error	Indoor or outdoor EEPROM data error	-	Rewrite EEPROM data of indoor unit or outdoor unit.
			5	EEPROM Mutual memory error	Indoor or outdoor EEPROM data error 2	-	Rewrite EEPROM data of indoor unit or outdoor unit.



Problem symptom	Outdoor unit indication (LED1)	Malfunction No.*		Content of diagnosis		Check point	Action				
		Main	Sub	Main	Sub						
Indoor and outdoor units do not operate.	11-time	11	0	Outdoor unit DC fan	Outdoor unit DC fan rotation error	1) Check connector CN3 of the outdoor unit DC fan motor for secure installation. 2) Check the outdoor unit fan motor for proper rotation. 3) Check fuse FUSE5. 4) Outdoor unit control PWB	1) Correct the installation. 2) Replace the outdoor unit fan motor. 3) Replace the outdoor unit control PWB assembly. 4) Replace the outdoor unit control PWB assembly.				
			1		Outdoor unit DC fan driver IC error	1) Check if the fan IPM terminal resistance values are uniform. 2) Outdoor unit fan motor continuity check.	1) Replace the outdoor unit control PWB assembly. 2) Replace the outdoor unit fan.				
			2		Outdoor unit DC fan lock error	1) Check if the fan IPM terminal resistance values are uniform. 2) 1): Normal	1) Replace the outdoor unit control PWB assembly. 2) Replace the outdoor unit fan.				
			3		Outdoor unit DC fan	Detection error of DC fan negative rotation before compressor is driven	1) (Temporary stop for DC fan circuit protection)	-			
			4			Detection error of inverter current for DC fan	-	1) Replace the outdoor unit control PWB assembly.			
			5			Outdoor unit DC fan open connector error	1) Check connector CN3 of the outdoor unit DC fan motor for secure installation. 2) No abnormality found in above inspection 1).	1) Correct the installation. 2) Replace the outdoor unit control PWB assembly.			
			Indoor and outdoor units do not operate.		12-time	12	0	Thermal fuse in terminal board	Thermal fuse error in terminal board (for power supply)	1) Check the thermal fuse in terminal board (for Power supply) 2) Check connector CN5 of the outdoor unit. 3) 1) 2): Normal	1) Replace terminal board for Power supply. 2) Correct the installation. 3) Replace the outdoor unit control PCB assembly.

Problem symptom	Outdoor unit indication (LED1)	Malfunction No.*		Content of diagnosis		Check point	Action
		Main	Sub	Main	Sub		
Indoor and outdoor units do not operate.	13-time	13	0	Compressor error	Compressor winding short circuit	-	Replace Compressor.
			1		Compressor winding open etc.		
			2		compressor Lock		
Indoor units operate.			3		over current pause		
Indoor and outdoor units do not operate.	14-time	14	0	Outdoor unit PAM	PAM over voltage error	1) Check the AC power supply voltage for fluctuation.	1) Correct the installation.
							2) No abnormality found in above inspection.
			1		PAM clock error	1) Check the PAM clock for proper input.	1) Replace the outdoor unit control PWB assembly.
					2	Abnormal power supply voltage / DC low voltage.	1) Check the AC power supply voltage for fluctuation.
			Indoor unit operates. Outdoor unit does not operate.		Lighting or OFF	17	0
	2) Check voltage between N and 1 the indoor/outdoor unit terminal boards.	2) Replace the outdoor unit control PWB assembly.					
	3) Check the outdoor unit fuse.	3) Replace the fuse/ outdoor unit control PWB assembly.					
	4) Check voltages of 15V-0V, 12V-0V and 5V-0V on the PWB. 15V-0V :15V 12V-0V :12V 5V-0V :5V Check resistance between IPM terminals.	4) Replace the outdoor unit control PWB assembly.					
	5) No abnormality found in above inspections 1) through 4).	5) Replace the outdoor unit control PWB board.					
Indoor unit operates. Outdoor unit does not operate.	Lighting or OFF	18	0	Wiring between units	Serial short-circuit	1) Check the wiring between units.	1) Correct the wiring.
Indoor and outdoor units do not operate.			1		Serial erroneous wiring	1) Check the wiring between units.	1) Correct the wiring.
Indoor and outdoor units can operate.			2		High speed serial error	-	Check the wiring between unit.

Problem symptom	Outdoor unit indication (LED1)	Malfunction No.*		Content of diagnosis		Check point	Action
		Main	Sub	Main	Sub		
Indoor and outdoor units do not operate.	Normal blinking or OFF	19	0	Indoor unit fan	Indoor unit fan error	1) Check the indoor fan motor for proper rotating operation.(Check fan lock.)	1) Replace the indoor fan motor.
						2) Check the lead wire of the indoor fan motor for open-circuit.	2) Replace the indoor fan motor.
						3) Check connector of the indoor unit fan motor for secure installation	3) Correct the installation of the indoor fan motor connector.
						4) No abnormality found in above inspections 1) through 3).	4) Replace the indoor unit control PWB
Indoor and outdoor units do not operate.	Normal blinking or OFF	20	0	Indoor unit control PWB	EEPROM data error	1) (EEPROM read data error)	1) Replace the indoor unit control PWB
			4	EEPROM Mutual memory error	Indoor or outdoor EEPROM data error	-	Rewrite EEPROM data of indoor unit or outdoor unit.
Indoor and outdoor units operate	Normal blinking or OFF	24	0	Wireless LAN	Wireless adapter communication error	1) Check Wireless adapter and related circuit.	1) Confirm assembly. 2) Confirm wireless adapter.
			1		Wireless router connection error	1) Check Wireless router. 2) Check Internet.	1) Confirm connecting with wireless router. 2) Confirm setting of wireless router. 3) Confirm connecting of internet.
			2		Internet communication error		
			3		communication with server error		
Indoor and outdoor units operate	Normal blinking or OFF	25	1	AC clock error	-	Check the circuit of making AC clock	Replace the indoor unit control PWB
Indoor and outdoor units operate	Normal blinking or OFF	26	1	Indoor unit room temperature thermistor	Indoor unit room temperature thermistor	1) Check connector of thermistor for secure installation. 2) Check the temperature properties of the thermistor.	1) Replace the thermistor.
			2	Indoor unit heat exchanger thermistor	Indoor unit heat exchanger thermistor		
			3	Indoor unit liquid pipe thermistor	Indoor unit liquid pipe thermistor		

4. OTHER MALFUNCTION ERROR INDICATIONS / BUZZERS

4.1 LED lamp indications during malfunction

MALFUNCTION	Blinking LED Lamps *Any LED lamp keeping lit and is not blinking indicates normal operation and setting				Main error code and details
	OPERATION (BLUE)	TIMER (ORANGE)	WLAN (GREEN)	PLASMA CLUSTER (BLUE)	
Serial open circuit					17, Serial open circuit
Wireless LAN adapter communication error					24, Wireless LAN adapter communication errors · Wireless adapter communication error · Wireless router connection error · Internet communication error · Server connection error

4.2 LED lamp indications during normal operation

INDICATION	Blinking LED Lamps					Notes
	OPERATION (BLUE)	OPERATION (GREEN)	TIMER (ORANGE)	WLAN (GREEN)	PLASMA CLUSTER (BLUE)	
Filter Cleaning Recommendation	Operation LED lamp blinks blue and green alternately.					Cumulative operation hours over 720 hours. Press ON/OFF button for 2 seconds to reset hours.
-27°C(-17°F) Auto OFF	Continuous blinking.					The unit turns off automatically when outside temperature is below -27°C (-17°F) and prevent damages to the outdoor unit.
Standby mode(only during multi zone system operation)	Operation LED lamp and TIMER lamp blinks alternately.					Indoor unit starts beeping at the same time. The unit may be set at a conflicting mode to other running unit.

4.3 Errors without indication

When EEPROM data has errors/problems at power supply connection, buzzer will beep continuously and all LED lamps remain OFF. Malfunction indications due to wiring error during installation.

	Inter-unit wiring error mode	Symptoms
1		The unit stops operation. Malfunction diagnosis displays nothing. (Remote control also displays nothing when malfunction code is called out.)
2		The unit stops operation. Malfunction diagnosis displays nothing. (Remote control also displays nothing when malfunction code is called out.)
3		The unit stops operation. Malfunction diagnosis displays "18-1". (Remote control also displays "18-1" when malfunction code is called out.)
4		The unit stops operation. Malfunction diagnosis displays nothing. (Remote control also displays nothing when malfunction code is called out.)
5		The unit stops operation. Malfunction diagnosis displays "18-1". (Remote control also displays "18-1" when malfunction code is called out.)

CHAPTER 5. REFRIGERATION CYCLE

[1] SCHEMATIC DIAGRAM AND REFRIGERANT FLOW

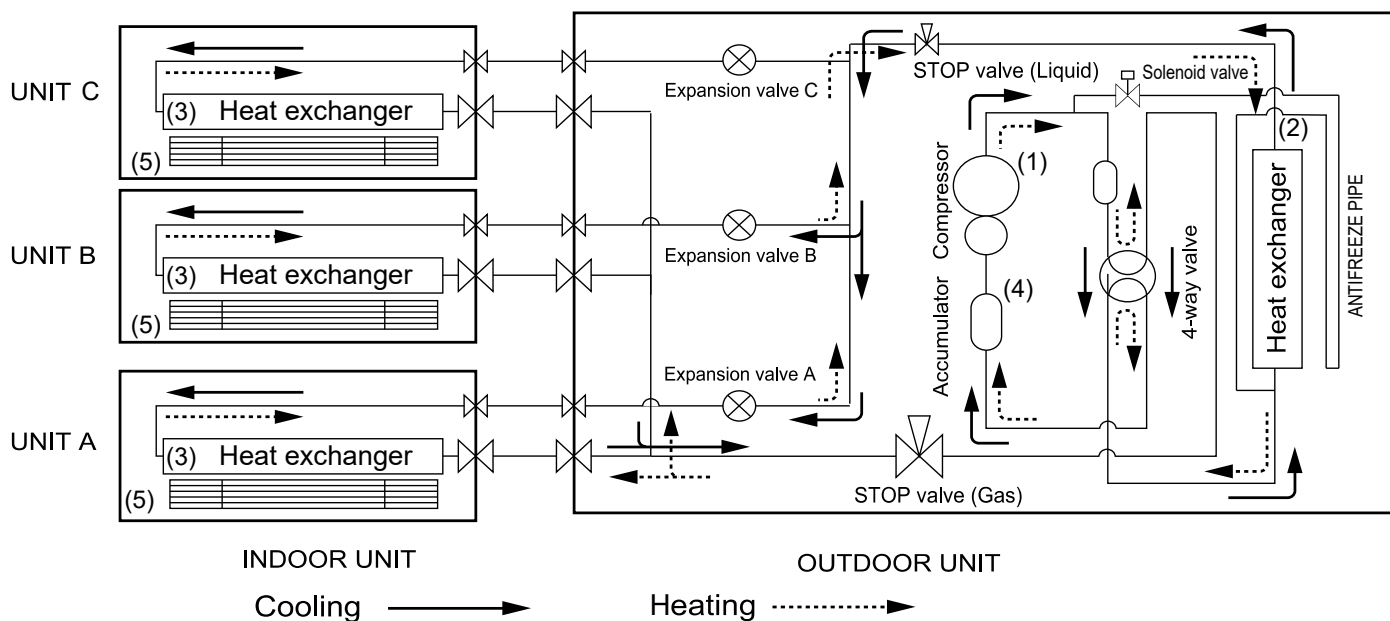

[2] STANDARD CONDITION

Temperature of each part and pressure of stop valve (Gas) are acquired in standard condition, and would change with condition around. The standard condition is as follows:

	Indoor side		Outdoor side	
	Dry-bulb Temp. (°F)	Relative Humidity (%)	Dry-bulb Temp. (°F)	Relative Humidity (%)
Cooling	80 (26.7)	50.7	95 (35)	-
Heating	70 (21.1)	-	47 (8.33)	72.7

[3] PEAK OPERATION CURRENT

If the current flowing in the heat pump exceeds the peak control current, the operation frequency is decreased until the current value drops below the peak control current.

	Cooling		Heating	
	< 104 °F (40°C)	≧ 104 °F (40°C)	< 63 °F (17°C)	≧ 63 °F (17°C)
Peak Current (A)	13.8	12.9	13.8	12.8

[4] TEMPERATURE AT EACH PART AND PRESSURE IN STOP VALVE (GAS)

Indoor fan speed is set to [High]

AC Voltage is set to 230V

Running Unit	Mode	Cooling		Heating	
		Max	Test Run	Max	Test Run
AY-XPC12CU& AY-XPC12CU& AY-XPC12CU	Compressor frequency (Hz)	68	51	82	79
	Temp. on (1) °F(°C)	186 (86)	174 (79)	171 (77)	168 (76)
	Temp. on (2) °F(°C)	97 (36)	97 (36)	37 (3)	37 (3)
	Temp. on (3) °F(°C)	56 (13)	60 (15)	74 (23)	74 (23)
	Temp. on (4) °F(°C)	53 (12)	61 (16)	31 (-1)	31 (-1)
	Outlet Air Temp. on (5) °F(°C)	61 (16)	64 (18)	94 (34)	93 (34)
	STOP valve (Gas) pressure PSIG (MPaG)	153 (1.1)	167 (1.2)	330 (2.3)	327 (2.3)
	AC current (A)	9.4	6.3	8.9	8.5

Running Unit	Mode	Cooling		Heating	
		Max	Test Run	Max	Test Run
AY-XPC9CU& AY-XPC9CU& AY-XPC9CU	Compressor frequency (Hz)	68	38	82	66
	Temp. on (1) °F(°C)	190 (88)	167 (75)	175 (79)	159 (71)
	Temp. on (2) °F(°C)	97 (36)	97 (36)	37 (3)	37 (3)
	Temp. on (3) °F(°C)	55 (13)	62 (16)	76 (24)	73 (23)
	Temp. on (4) °F(°C)	53 (12)	65 (19)	31 (-1)	34 (1)
	Outlet Air Temp. on (5) °F(°C)	60 (15)	65 (18)	96 (35)	91 (33)
	STOP valve (Gas) pressure PSIG (MPaG)	151 (1)	175 (1.2)	339 (2.3)	311 (2.1)
	AC current (A)	9.3	4.9	9.0	6.8

Running Unit	Mode	Cooling		Heating	
		Max	Test Run	Max	Test Run
AY-XPC18CU(-B)& AY-XPC18CU(-B)	Compressor frequency (Hz)	68	66	82	82
	Temp. on (1) °F(°C)	193 (90)	190 (88)	164 (74)	164 (74)
	Temp. on (2) °F(°C)	97 (36)	97 (36)	36 (2)	36 (2)
	Temp. on (3) °F(°C)	61 (16)	61 (16)	72 (22)	72 (22)
	Temp. on (4) °F(°C)	59 (15)	60 (16)	31 (-1)	31 (-1)
	Outlet Air Temp. on (5) °F(°C)	61 (16)	61 (16)	90 (32)	90 (32)
	STOP valve (Gas) pressure PSIG (MPaG)	154 (1.1)	155 (1.1)	311 (2.1)	311 (2.1)
	AC current (A)	9.3	8.9	8.7	8.7

Running Unit	Mode	Cooling		Heating	
		Max	Test Run	Max	Test Run
AY-XPC18CU(-B) (1 unit only on operation)	Compressor frequency (Hz)	62	35	82	50
	Temp. on (1) °F(°C)	195 (90)	175 (80)	162 (72)	126 (52)
	Temp. on (2) °F(°C)	95 (35)	96 (36)	38 (3)	37 (3)
	Temp. on (3) °F(°C)	51 (11)	57 (14)	100 (38)	90 (32)
	Temp. on (4) °F(°C)	44 (7)	60 (15)	31 (0)	37 (3)
	Outlet Air Temp. on (5) °F(°C)	56 (13)	61 (16)	106 (41)	93 (34)
	STOP valve (Gas) pressure PSIG (MPaG)	127 (0.9)	157 (1.1)	426 (2.9)	332 (2.3)
	AC current (A)	8.0	4.4	10.5	5.5

AY-XPC12CU etc. & AE-X3M24CU

Running Unit	Mode	Cooling		Heating	
		Max	Test Run	Max	Test Run
AY-XPC12CU (1 unit only on operation)	Compressor frequency (Hz)	41	23	67	34
	Temp. on (1) °F(°C)	190 (88)	162 (72)	177 (81)	147 (64)
	Temp. on (2) °F(°C)	96 (35)	95 (35)	39 (4)	34 (1)
	Temp. on (3) °F(°C)	50 (10)	56 (14)	96 (36)	103 (40)
	Temp. on (4) °F(°C)	48 (9)	61 (16)	37 (3)	39 (4)
	Outlet Air Temp. on (5) °F(°C)	57 (14)	62 (17)	117 (47)	92 (33)
	STOP valve (Gas) pressure PSIG (MPaG)	126 (0.9)	136 (0.9)	489 (3.4)	345 (2.4)
	AC current (A)	5.2	3.0	9.4	3.6

Running Unit	Mode	Cooling		Heating	
		Max	Test Run	Max	Test Run
AY-XPC9CU (1 unit only on operation)	Compressor frequency (Hz)	31	17	50	25
	Temp. on (1) °F(°C)	173 (78)	160 (71)	155 (69)	155 (68)
	Temp. on (2) °F(°C)	95 (35)	95 (35)	36 (2)	39 (4)
	Temp. on (3) °F(°C)	53 (12)	51 (10)	116 (47)	72 (22)
	Temp. on (4) °F(°C)	49 (9)	55 (13)	38 (3)	41 (5)
	Outlet Air Temp. on (5) °F(°C)	59 (15)	57 (14)	107 (42)	89 (32)
	STOP valve (Gas) pressure PSIG (MPaG)	140 (1)	142 (1)	418 (2.9)	320 (2.2)
	AC current (A)	3.9	2.2	6.1	2.9

[5] PERFORMANCE CURVES

- 1) Capacity , Power consumption and Outlet air temperature with 3 units (12k+12k+12k) running.
- 2) Indoor fan speed is set to [High].
- 3) Indoor air temperature: Cooling: 80°F(26.7°C), Heating: 70°F(21.1°C).
- 4) Power source: 230V, 60Hz
- 5) Performance corresponding to change in outside temperature when compressor is fixed to rated operation.

COOLING

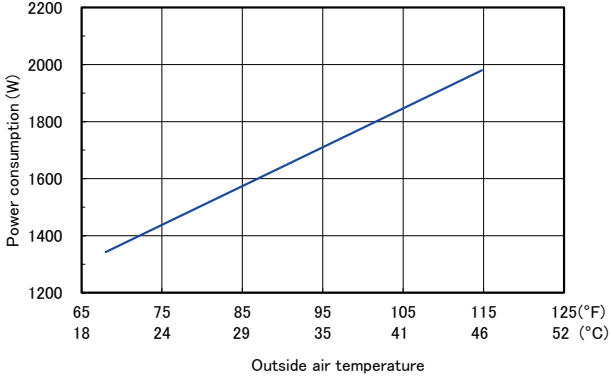

HEATING

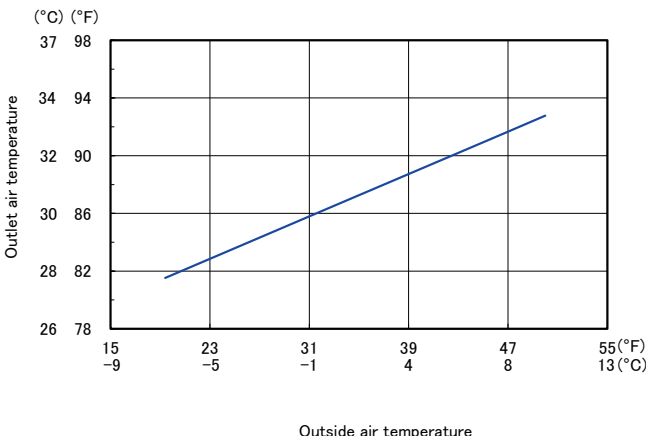
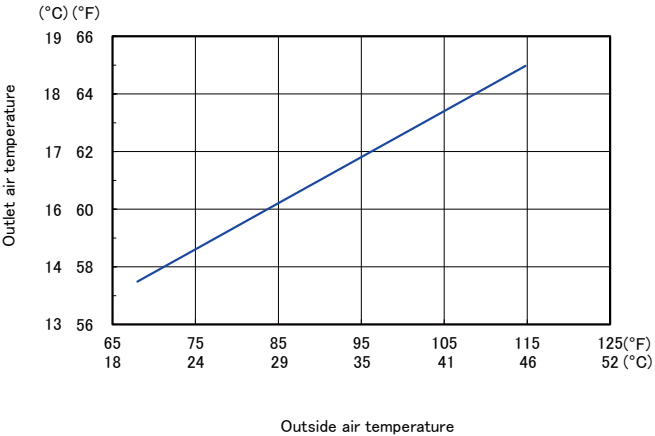
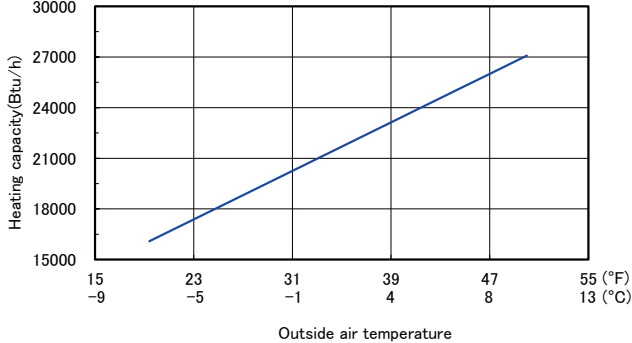
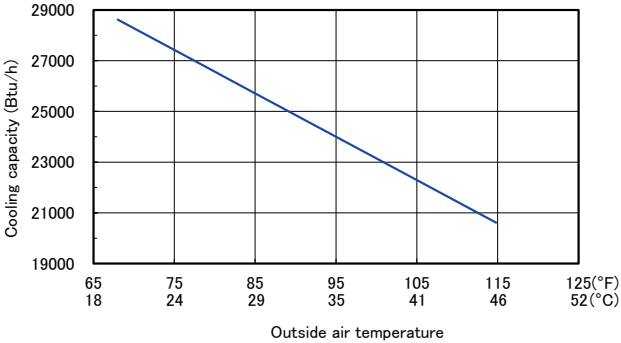
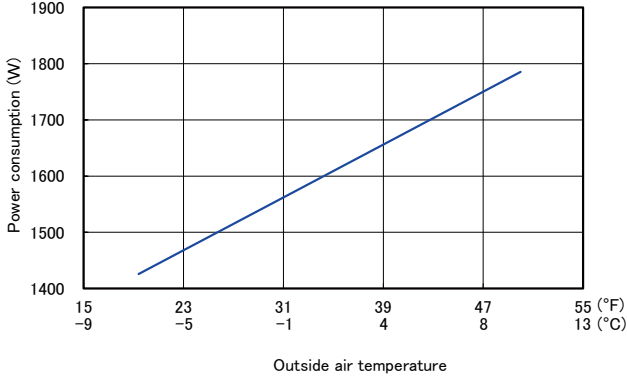

CHAPTER 6. DISASSEMBLY PROCEDURE

When carrying out repairs and modifications that require the use of arc- and flame-producing equipment such as welding, brazing, and soldering apparatus, ensure the work area is thoroughly ventilated before beginning. During the work, keep any mechanical ventilation systems in constant operation and all windows and doors open. For repairs involving parts of the refrigerant circuit, not only the technician, but also an additional observer must be present to monitor and assist with the procedure.

Necessary protective equipment must be available. When working with open flames or arcs, keep fire extinguishing equipment readily accessible. Only qualified technicians may perform welding and brazing operations.

Always disconnect the power cord from the AC power outlet before starting disassembly procedures. When reassembling the unit after repairs, reinstall all screws in their original positions. Note that screws may differ in specifications including corrosion-resistant treatment, tip shape, and length.

The screws used are not the same in specifications such as corrosion-resistant treatment, tip shape and length.

After completing heat pump repairs or part replacements, measure the insulation resistance of the equipment using an insulation resistance meter. If the measured resistance is below 1 MΩ, inspect all components and repair or replace any defective parts.

[1] INDOOR UNIT

1. MAIN UNIT (For AY-XPC9/12CU/12CQ models)

1) Lift Top Grille by the handles and remove it.

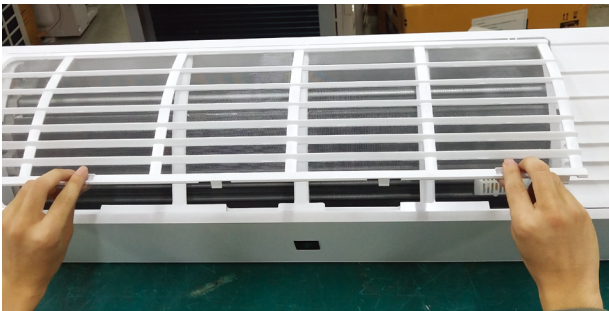

2) Remove Open Panel as below step.

- Unlock Panel Lock (Right and left side).

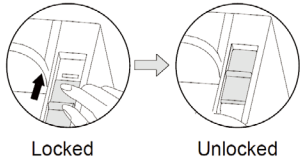

- Lift the Open Panel, then slide Open Panel's Hook along the guides on both sides to remove it.

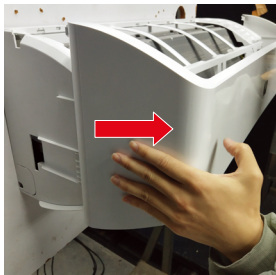
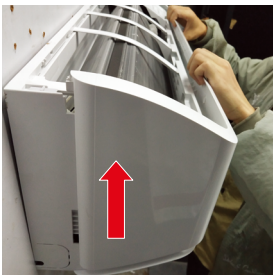

3) Remove a screw fixing the Cord Holder, then pry open the Cord Holder and remove it.



4) Loosen the screw on Terminal Board to remove unit-to-unit wiring.

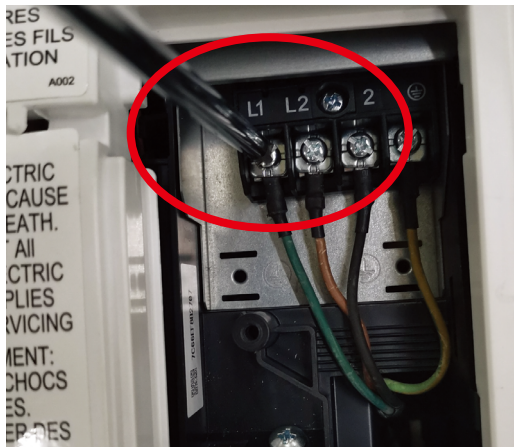

AY-XPC12CU etc. & AE-X3M24CU

5) Remove the Horizontal louver.

- Lift and remove the central shaft of the Horizontal louver.

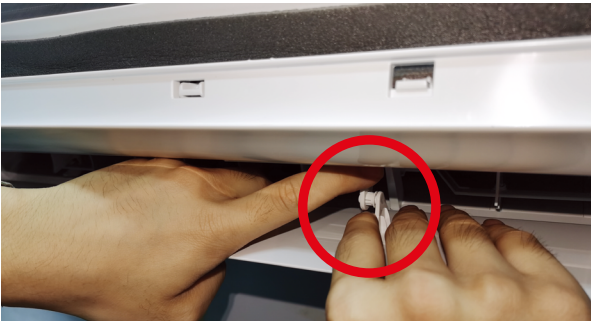

- Take it out from the left side by shaking the Horizontal louver.



- Take it out by moving the Horizontal louver to left side.



6) Remove two screws fixing the Front Panel.

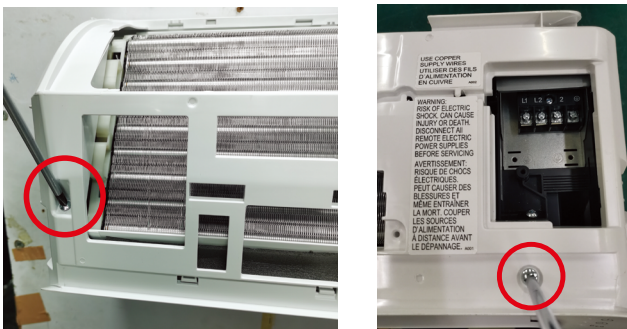

- Pull the top side of Front Panel to release the hooks.

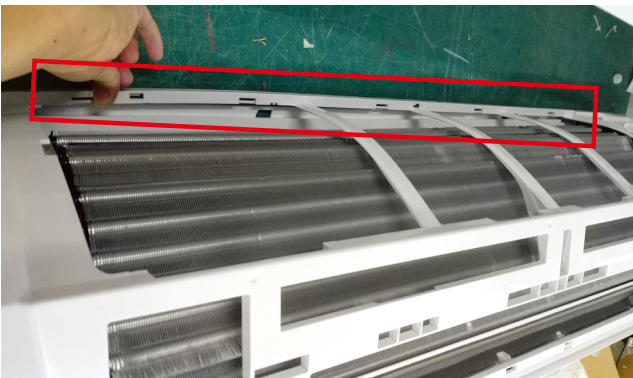

- Pull the bottom side to release these hooks.

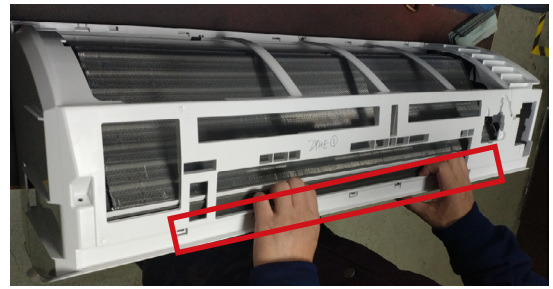

- Press below areas to release the Front Panel from inside hooks, then pull the Front Panel out.



7) Cut the wire fixing bands and remove the Thermistor.

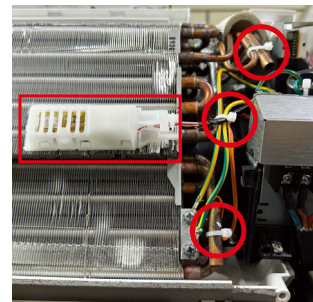

8) Remove two screws fixing the earth wire.

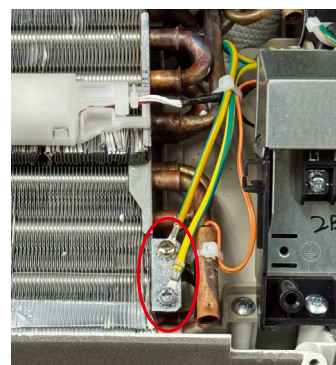

9) Remove the Control Box Cover.

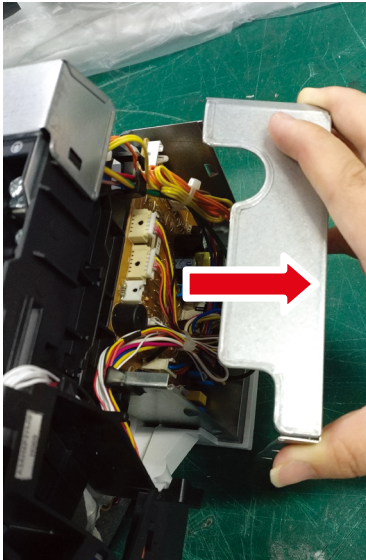

10) Cut two bands and remove all the connectors.

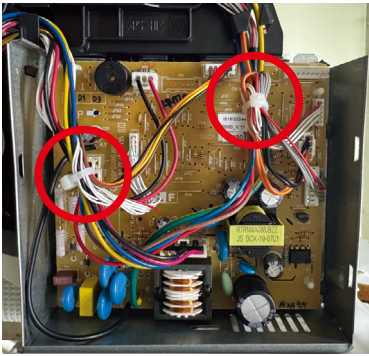

11) Remove one screw near Terminal Board as below, then rotate the Terminal Holder to take it out.

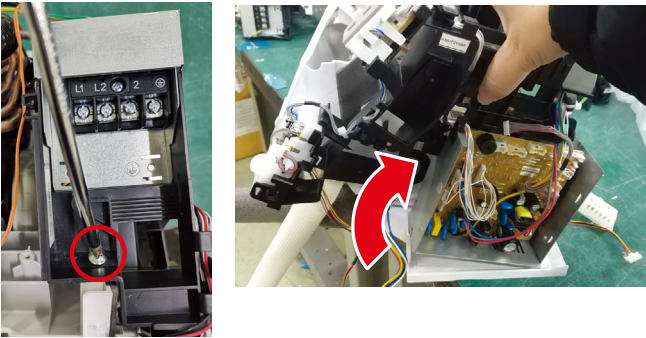

12) Use a pincer to press four spacers into the Control Angle to remove the PWB.

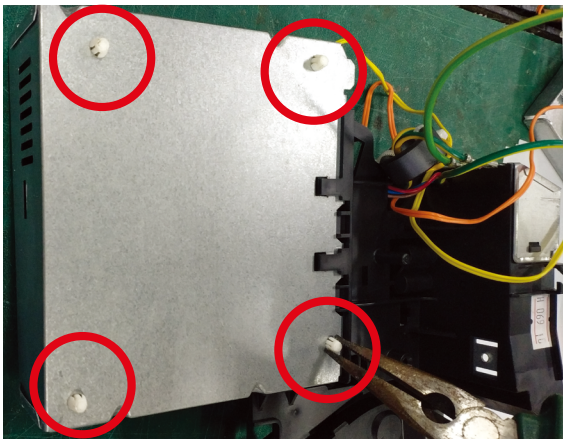

13) Release the hook of PCI Cover, take PLASMACLUSTER Unit out. Unlock the connector to remove the PLASMACLUSTER Unit.

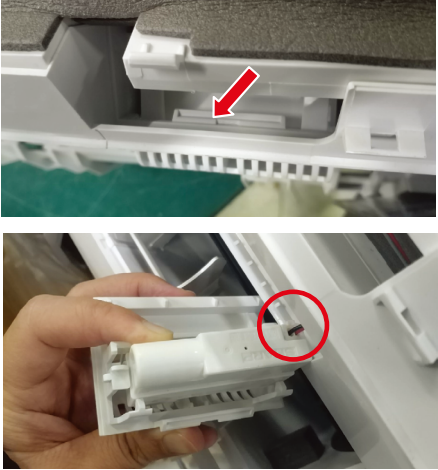

14) Remove the screw of Louver Motor, then take the Motor out.

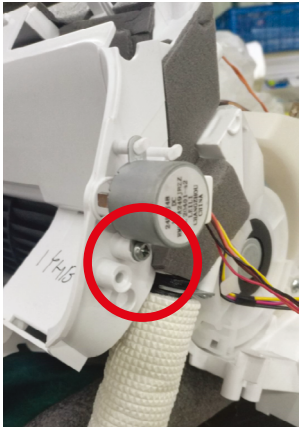

15) Release Arm Auto/Manual from Louver Link R.



16) Remove two screws, then remove Motor Cover.

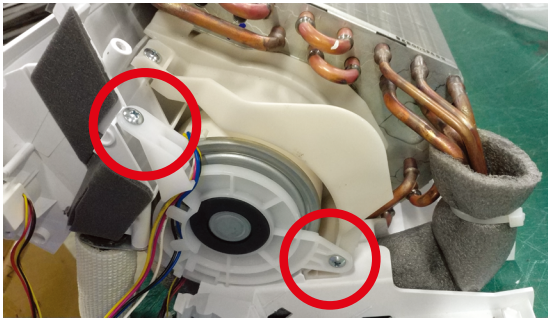

AY-XPC12CU etc. & AE-X3M24CU

17) Remove one screw between Cross Flow Fan and Fan Motor.

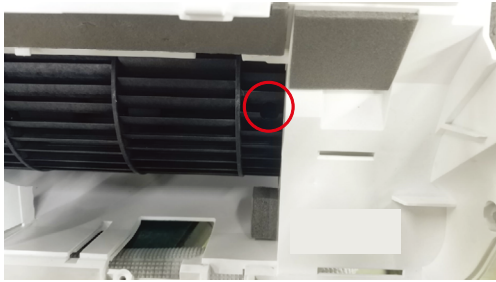

18) Take Fan Motor out by holding and pressing the Cross Flow Fan to left side as much as possible.

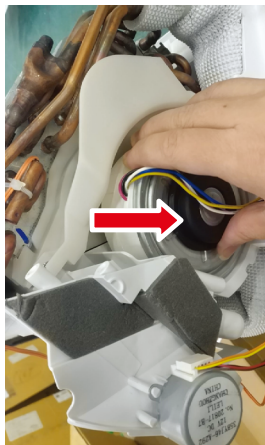
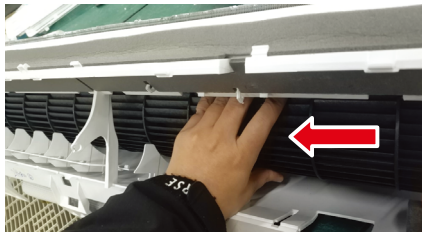

19) Remove one screw on Side Cover R.



20) Remove two screws fixing Side Cover L.

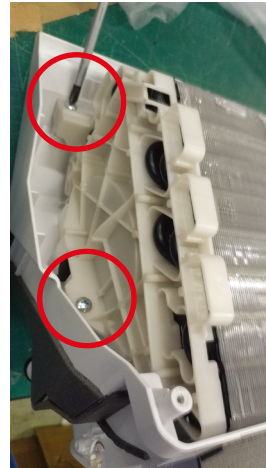

21) Push the Pipe Holder to remove it.



22) Widen the angle between Pipe Dan-S and Cabinet Sub. Then take the Evaporator out.

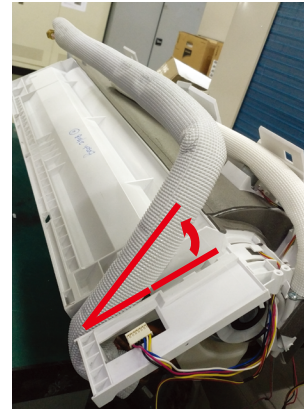

23) Take Cross Flow Fan out.



2. MAIN UNIT (For AY-XPC18CU,AY-XPC18CU-B model)

1) Lift Top Grille by the handles and remove it.

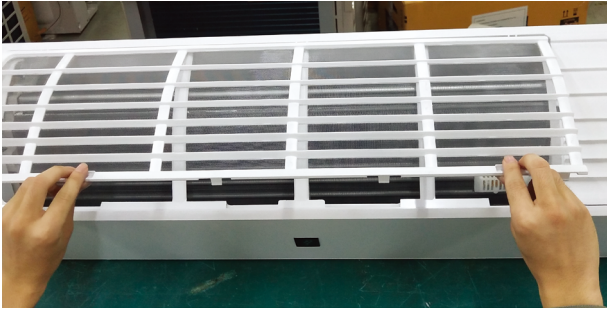

2) Remove Open Panel as below step.

- Unlock Panel Lock (Right and left side).

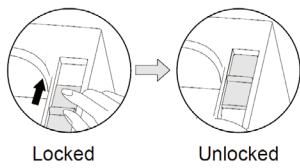

- Lift the Open Panel, then slide Open Panel's Hook along the guides on both sides to remove it.



3) Remove a screw fixing the Cord Holder, then pry open the Cord Holder and remove it.



4) Loosen the screw on Terminal Board to remove unit-to-unit wiring.

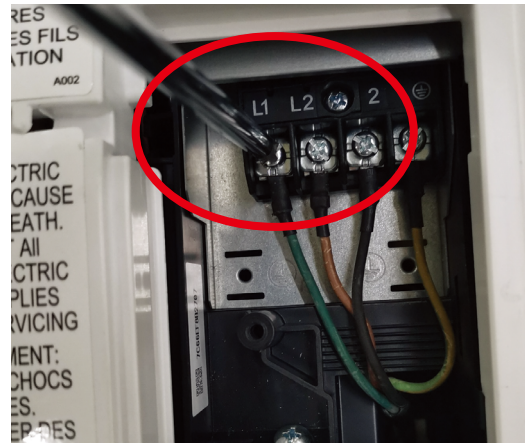

5) Remove the Horizontal Louver.

- Lift and remove the central shaft of the Horizontal louver.

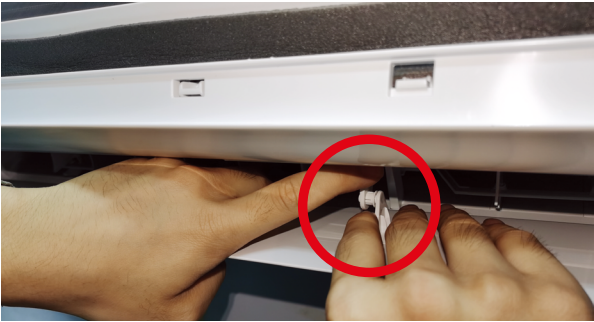

- Take it out from the left side by shaking the Horizontal louver.



- Take it out by moving the Horizontal louver to left side.



6) Remove two screws fixing the Front Panel.

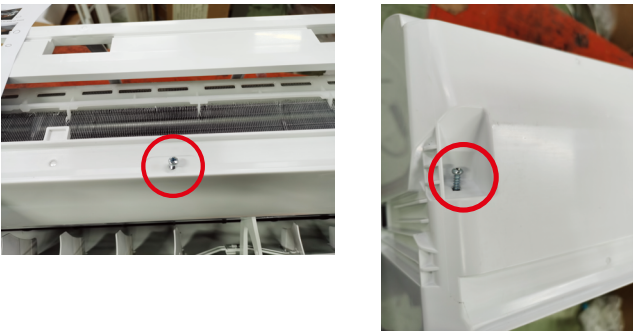

- Pull the top side of Front Panel to release the hooks.



- Pull the bottom side to release these hooks.



- Press below areas to release the Front Panel from inside hooks, then pull the Front Panel out.



7) Cut the Wire Fixing Bands and remove Thermistor.

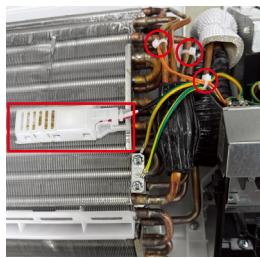

8) Remove two screws fixing the earth wire.

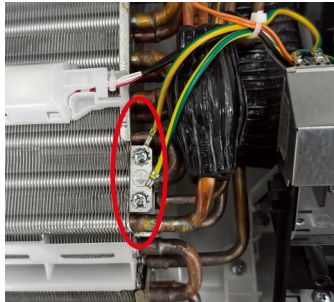

9) Remove the Control Box Cover.

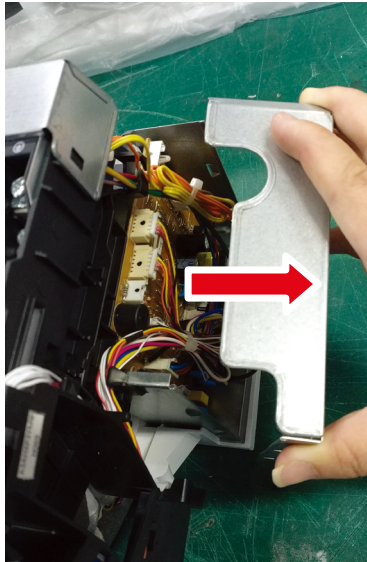

10) Cut two bands and remove all the connectors.

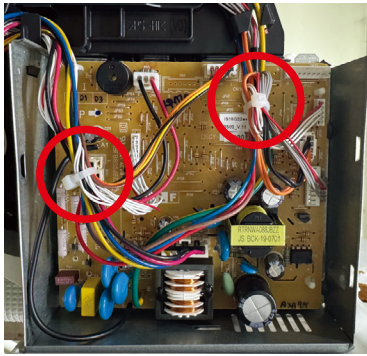

11) Remove one screw near Terminal Board as below, then rotate the Terminal Holder to take it out.

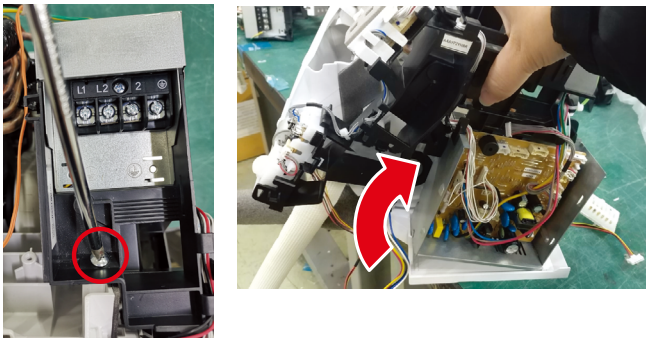

12) Use a pincer to press four spacers into the Control Angle to remove the PWB.

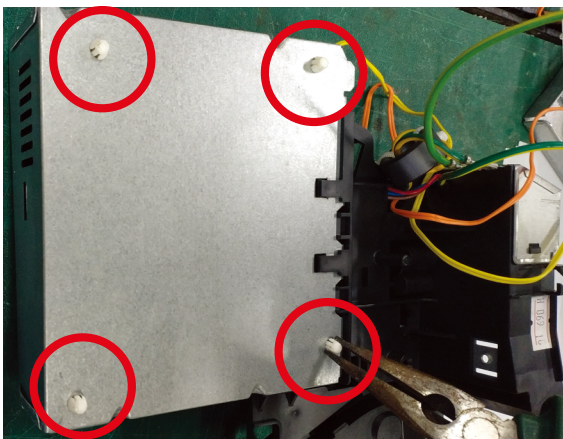

13) Remove one screw on Side Cover R.



14) Remove two screws on Side Cover L.



15) Push the Pipe Holder to remove it.



16) Widen the angle between Pipe Dan-S and Cabinet Sub. Then take the Evaporator out.

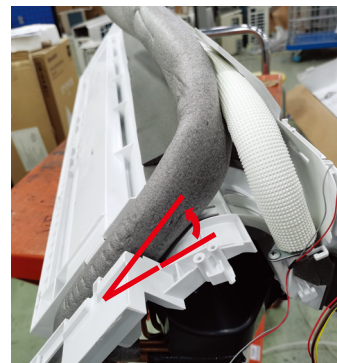

17) Release two hooks of Stabilizer R, and take Stabilizer R out. Unlock the connector to remove the PLASMACLUSTER Unit.

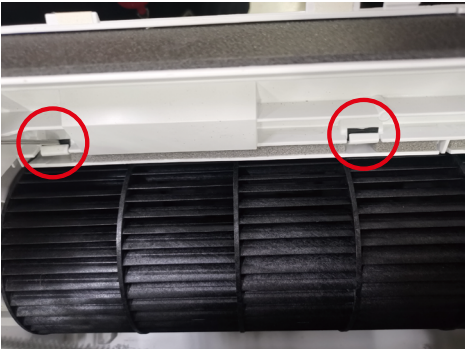

20) Remove two screws, then remove Motor Cover.

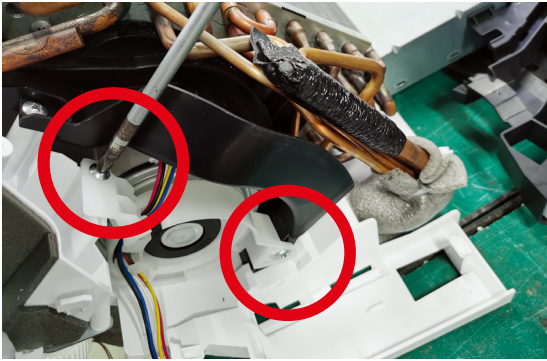

21) Remove one screw between Cross Flow Fan and Fan Motor.



22) Take Fan Motor out by holding and pressing the Cross Flow Fan to left side as much as possible.



18) Remove the screw of Louver Motor, then take the Louver Motor out.

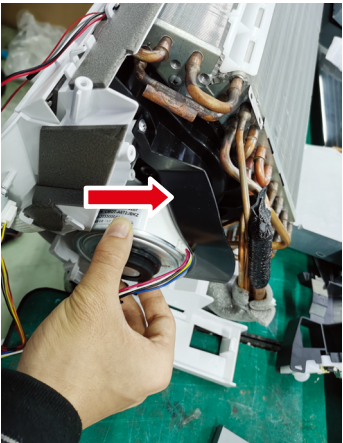

19) Release Arm Auto/Manual from Louver Link R.

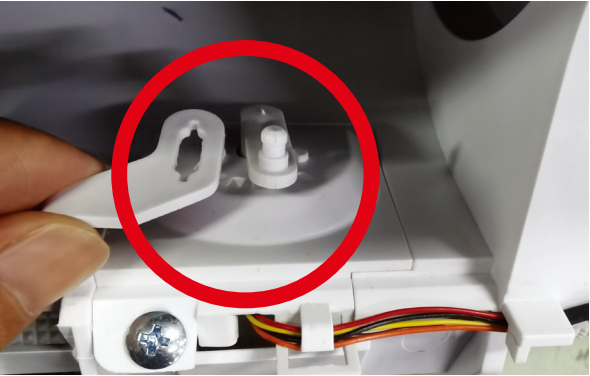

23) Take Cross Flow Fan out.



3. REPLACE WIRELESS ADAPTER

Maintenance shall be made by service personnel full of knowledge about wireless LAN.
Please contact SHARP for replacement.

- 1) Remove the Connector of Wireless adapter, and take it off from Control unit.

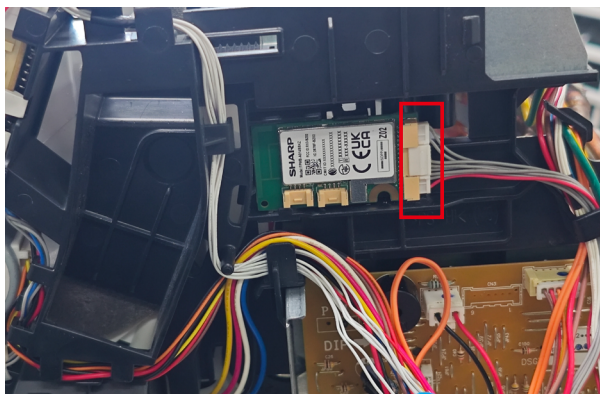

- 2) Replace the Wireless adapter by S-Z02 WF PWB Unit.
Note:The S-Z02 WF PWB Unit contains a wireless adapter and a QR label for service.

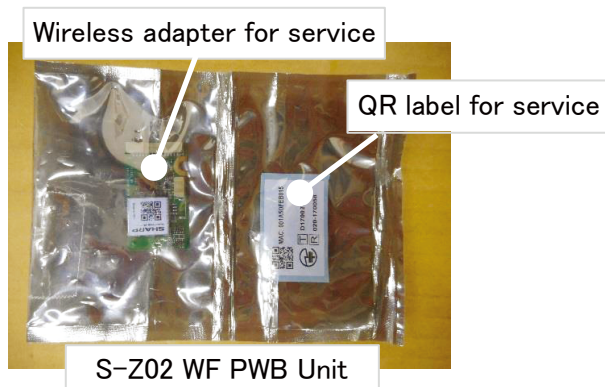

- 3) Patse the QR label for service to the bottom of indoor unit to replace the old QR label.



Old QR label
on the bottom of indoor unit



QR label for service

- 4) It's necessary to make the Wireless Lan connecting setting again.
Please finish the initial connection setting after replaced wireless adapter, the procedure is same as when you just bought the heat pump.

[2] OUTDOOR UNIT

Be sure to disconnect the power cord from the AC power outlet before starting the disassembly procedure. When reassembling the unit after repair, ensure all screws are reinstalled in their original positions.

The screws used vary in specifications, such as corrosion-resistant treatment, tip shape and length.

After completing heat pump repairs or part replacements, measure the insulation resistance of the equipment using an insulation resistance meter. If the measured resistance is below 1 MΩ, inspect all components and repair or replace any defective parts.

1. MAIN UNIT

1.Remove three screws fixing the Side Cover, then slide it downward to take it out.

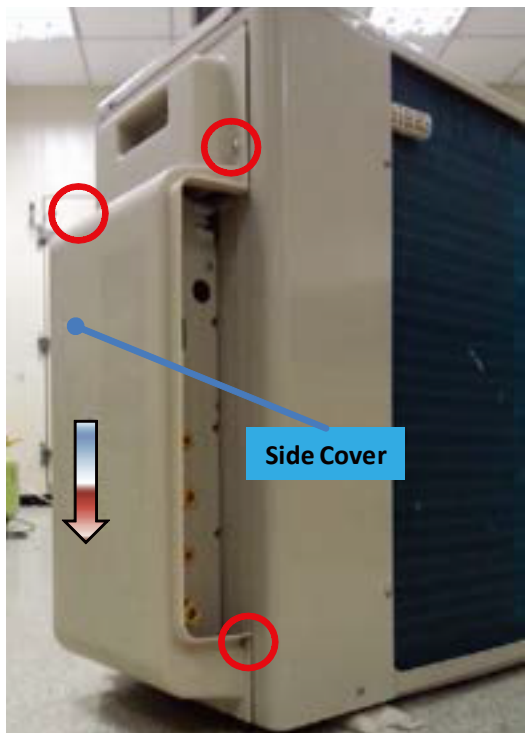

3.Remove eight screws, then lift the Top Plate to take it out.

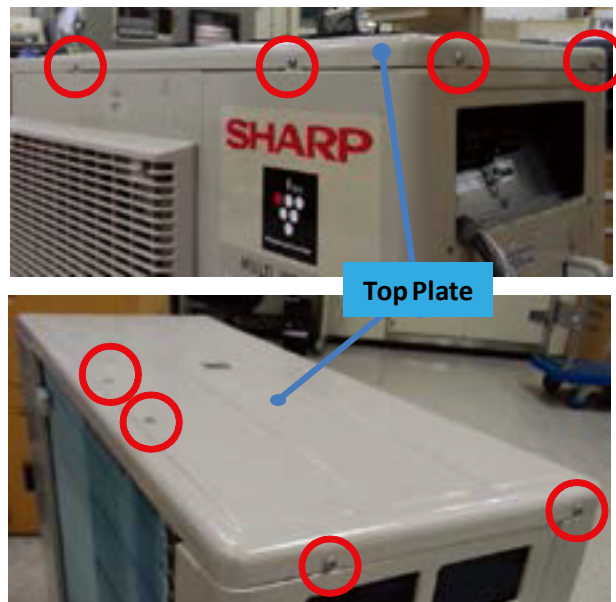

2.Remove two screws fixing Cable Cover, then slide it upward to take it out.

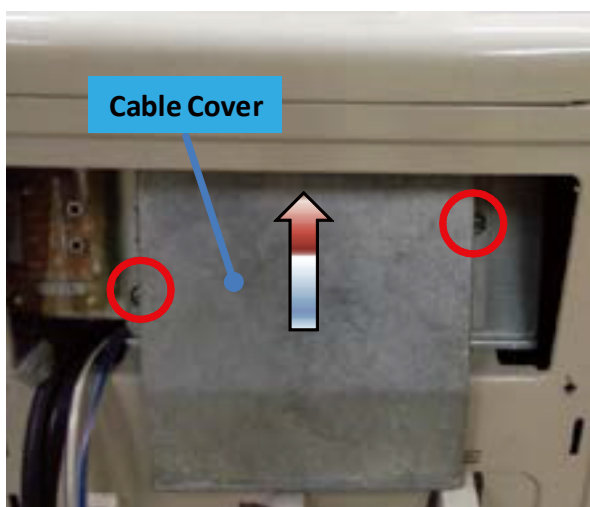

4.Remove the screw fixing Front Panel R, then slide it downward to take it out.

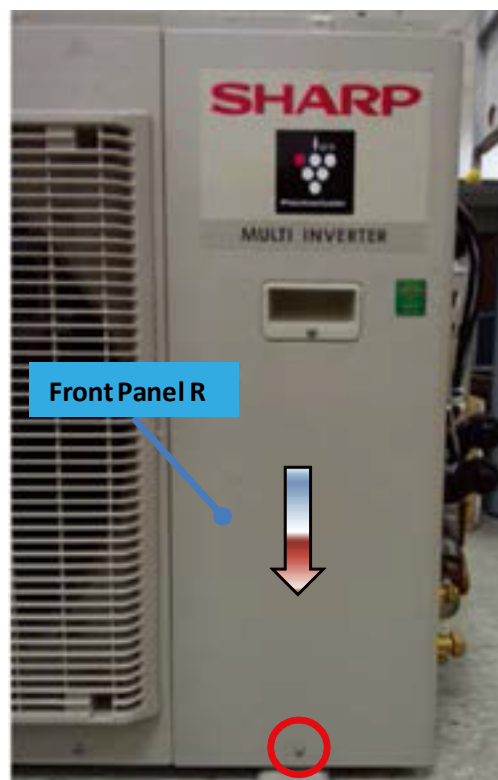

5.Remove two screws fixing the Angle then take it out.

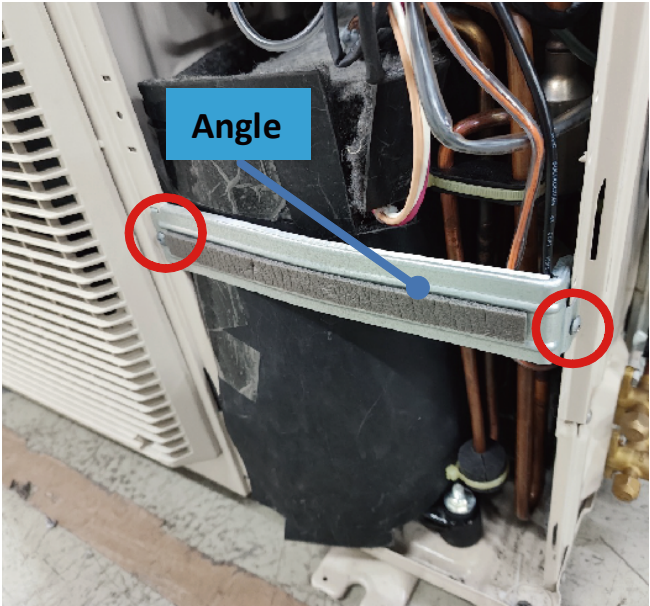

6. 3) Open the right side of the Panel.

4) Lift the left side of the Panel.

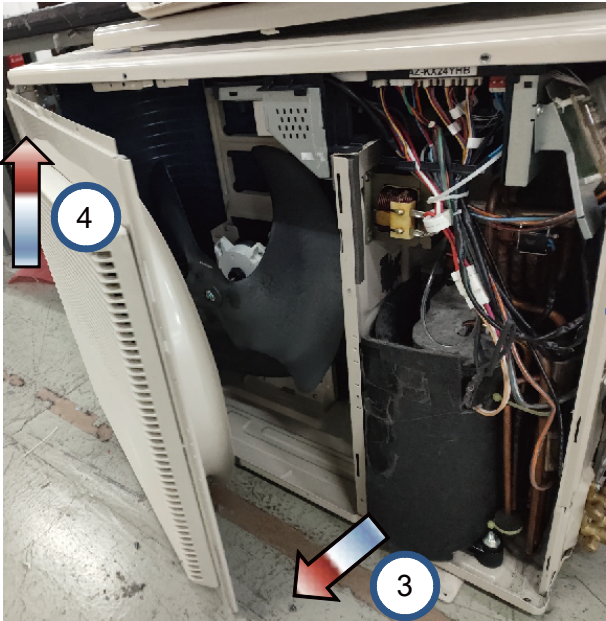

6. 1) Remove six screws fixing Front Panel L.

2) Remove the Front Panel L from Motor Angle T, then lift.

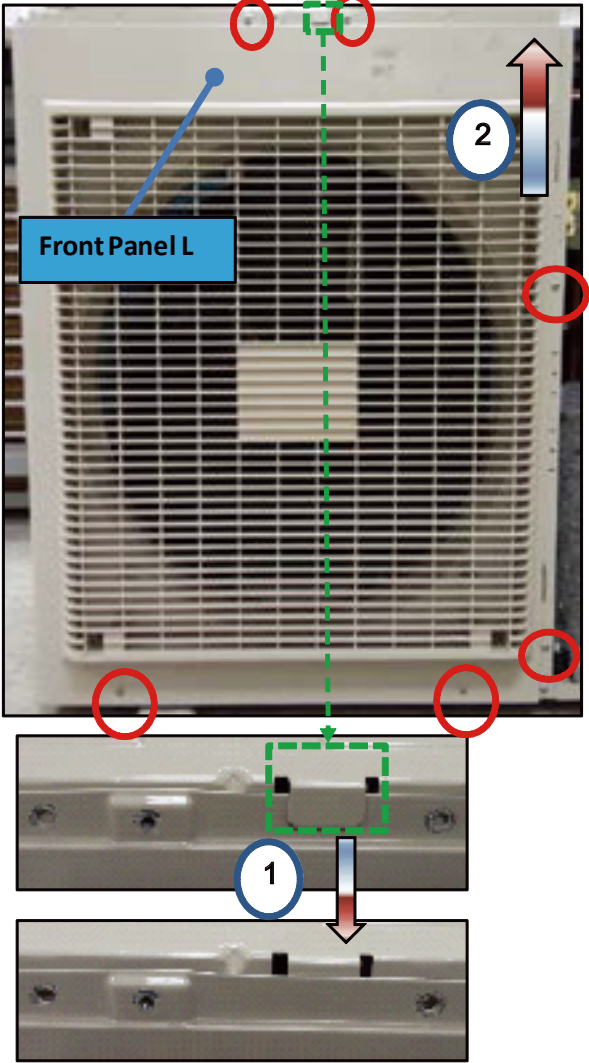

7.Remove Compressor Cover Top and Compressor Cover.

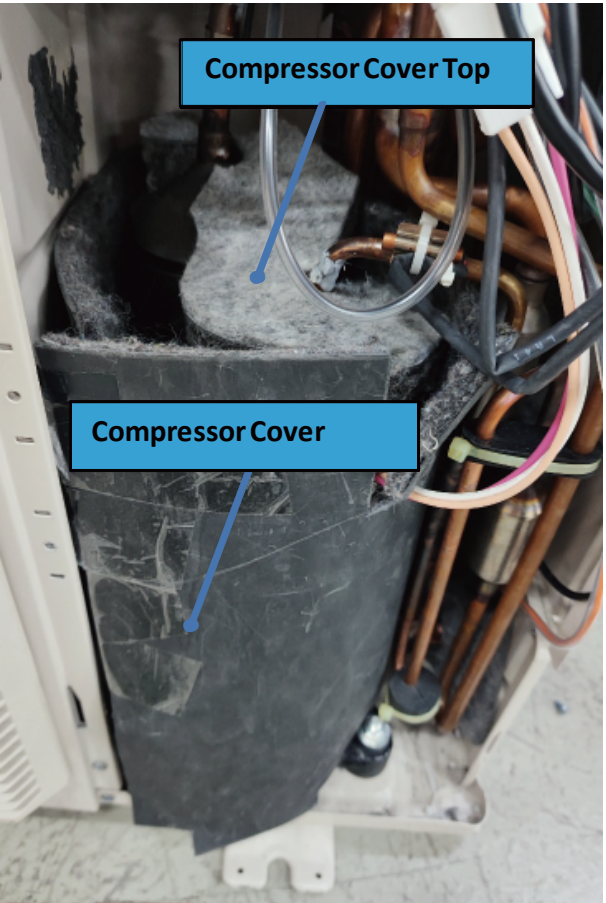

8.Remove the nut, then take Terminal Cover out.

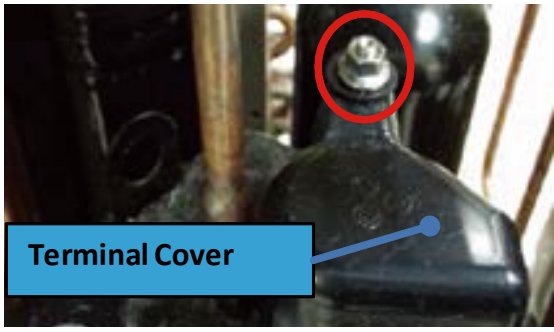

9.Take off three terminals on Compressor. (Orange, white, red)



10. 1) Take off nine connectors and two Reactor terminals, then cut three fixing bands.

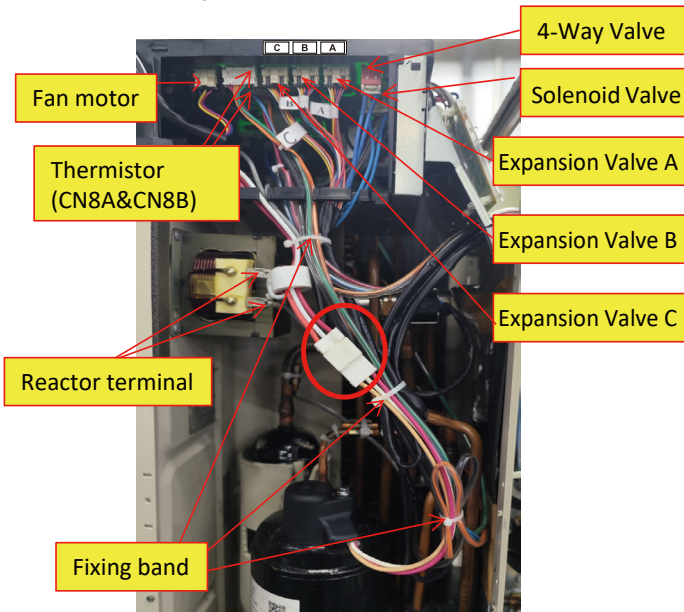

10. 2) Cut the fixing band and remove three screws fixing Control Box, and take Control Box out.

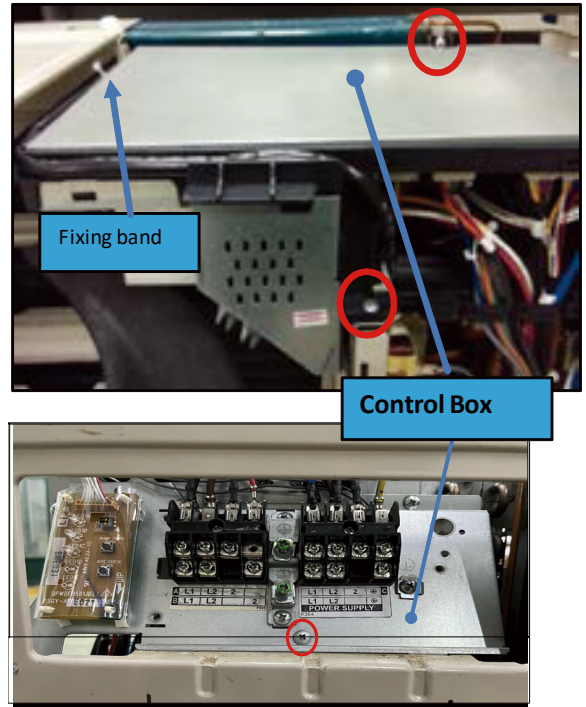

11. 1) Remove eleven screws fixing the Side Cabinet R. Release two hooks to free the wires.

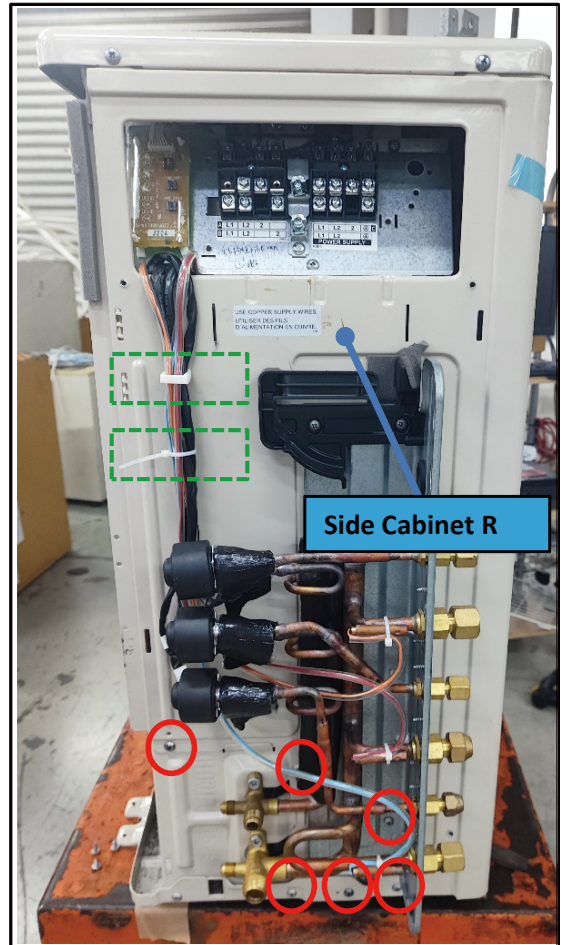

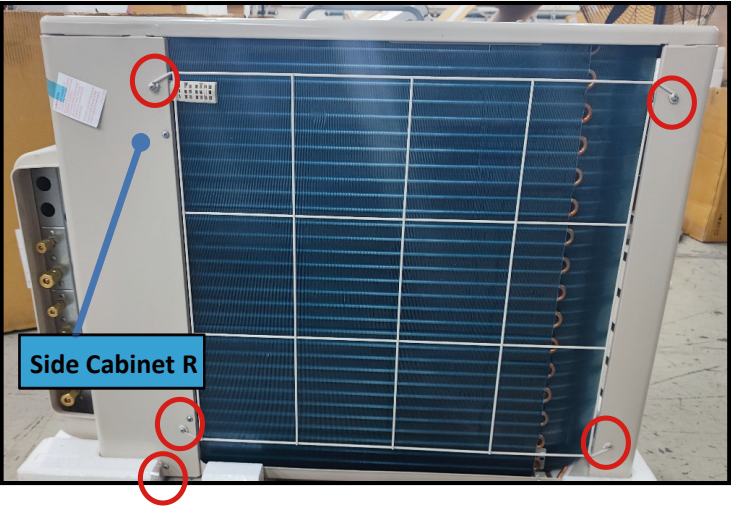

11. 2) Lift Side Cabinet R, then slide to the right to take it off.

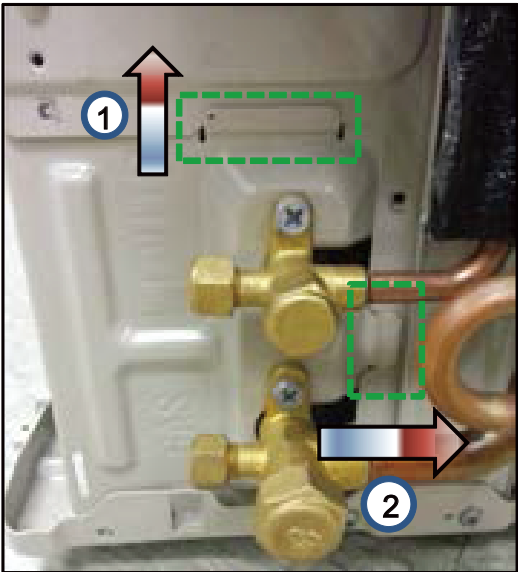

12. Remove three screws fixing Side C abinet L then take it out.

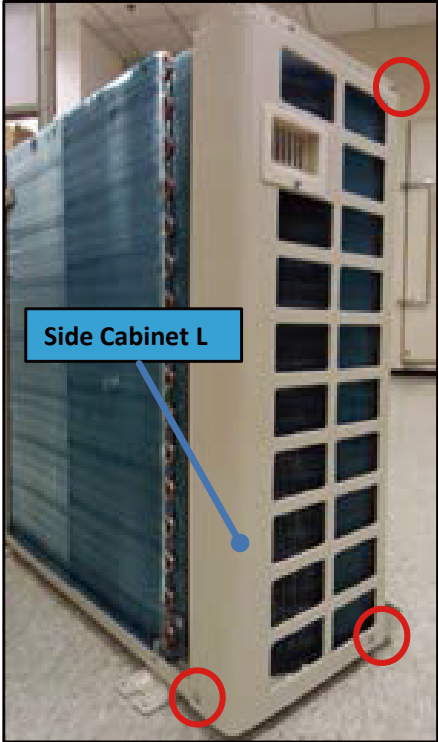

13. Remove two screws fixing the Bulkhead, then lift it to take out.

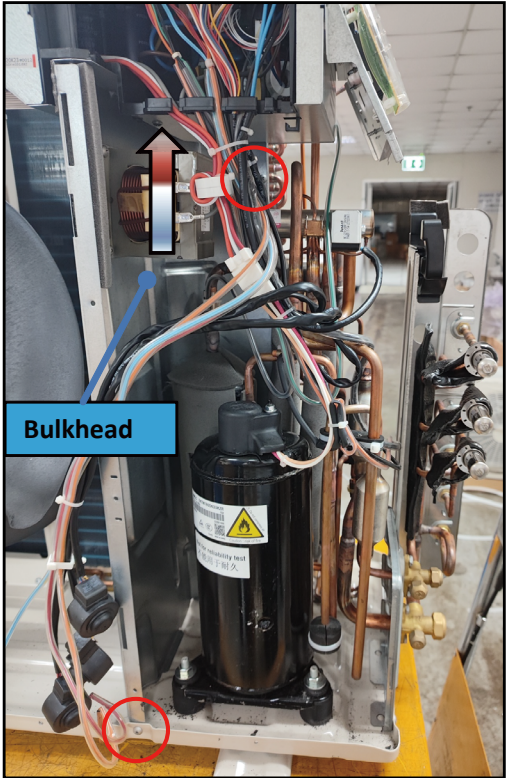

14. Remove four screws fixing the Reactor, then take it out.

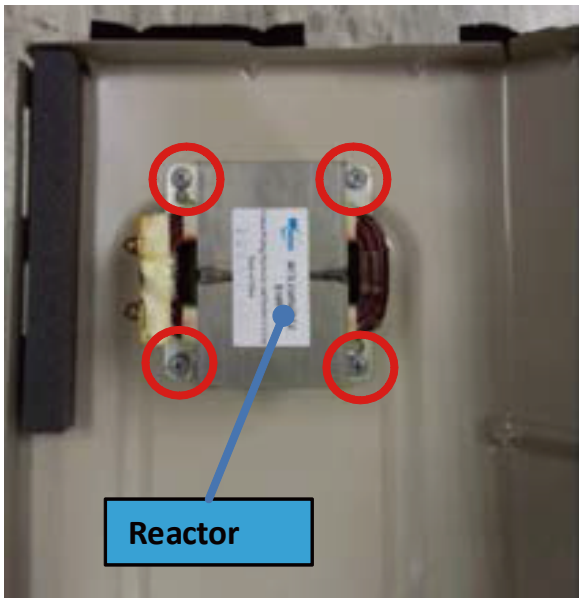

17. Remove two screws fixing Motor Angle, then pull and slide it to remove.

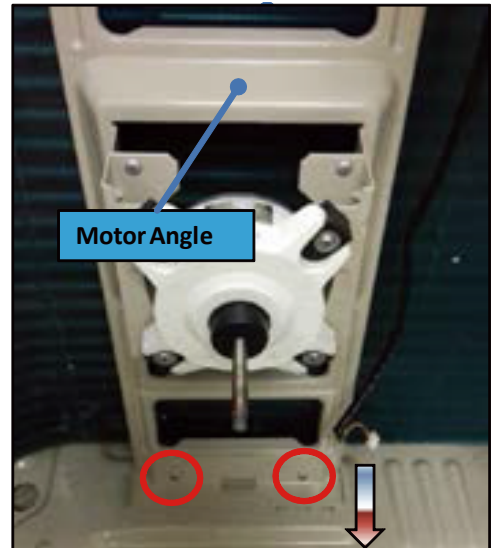

15. Remove two screws fixing Motor Angle T, then take it out.

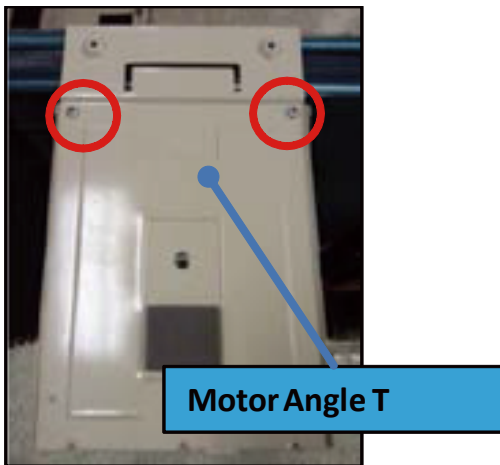

18. 1) Cut the fixing band and release the wire.

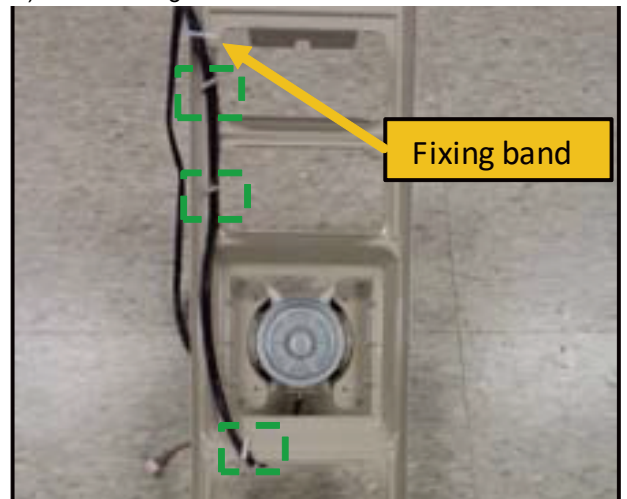

16. Remove a nut fixing Propeller Fan then take it out.

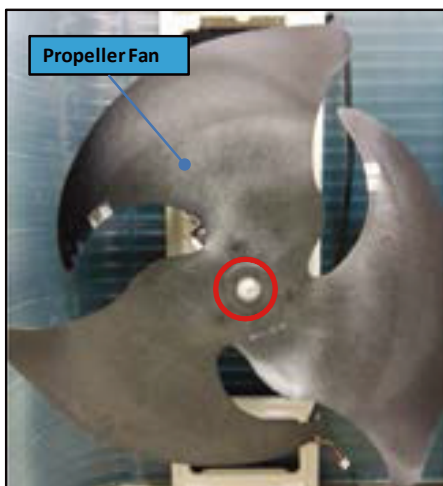

18. 2) Remove four screws fixing Motor, then take it out.

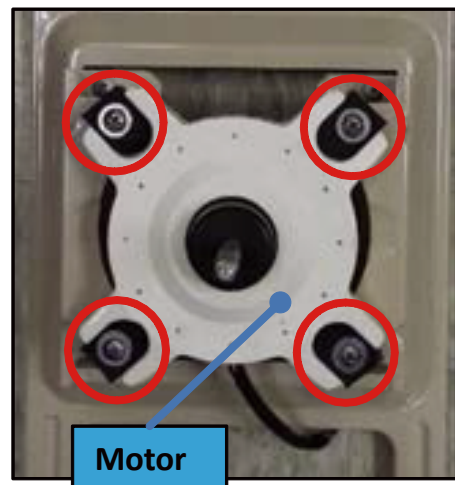

2. DISASSEMBLY OF CONTROL BOARD UNIT

If the outdoor main board is replaced with a service board, be sure to perform a wire check.

1.Take off terminal board thermal fuse from CN2.

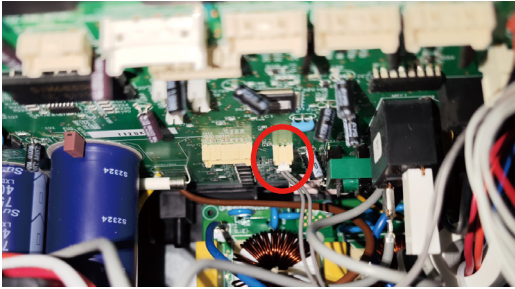

2.Remove four screws, then remove the Terminal Board.

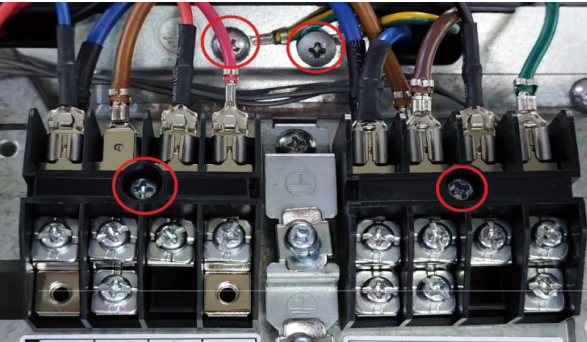

3.Take off display board terminal from CN11.

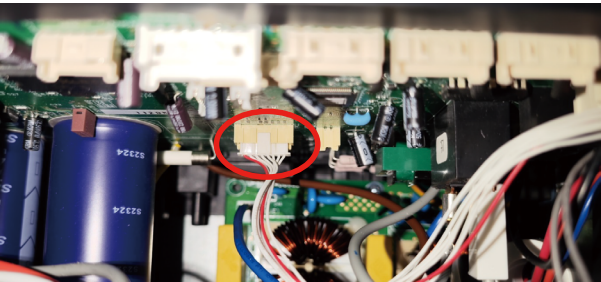

4.Remove four spacers and two screws, release the Display Board hook, then remove the Terminal Board Holder.

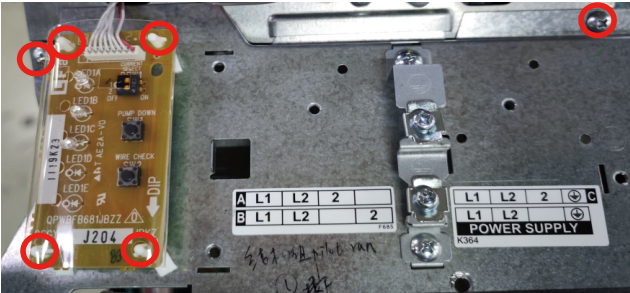

5.Remove the Control Box Cover from hook.

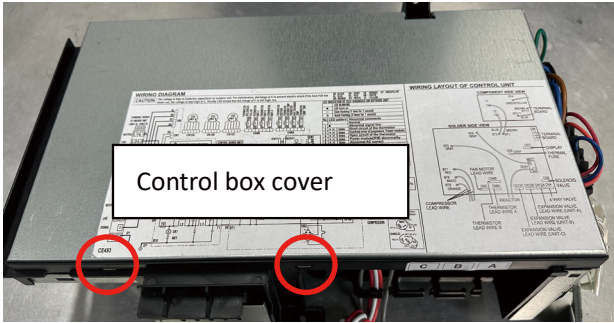

6.Remove seven screws and disconnect CN6, then take out the Control Unit Board.

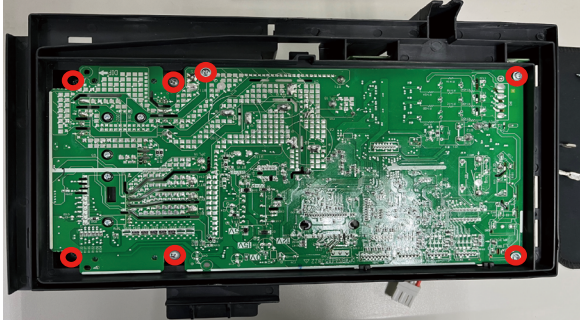

7.Remove wires from T1 and T2, remove a screw to take out the Filter Board.

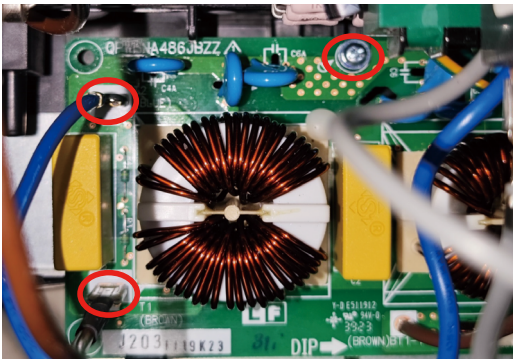

Failure diagnosis flowchart

Table of contents

Error code	Contents
1	Short circuit of ODU thermistor
2	Overheat error (Compressor or cycle)
5	Open circuit of ODU thermistor
6	DC current error
7	AC current error
9	Cycle error
9-5	2 way/3 way close valve
9-6	Solenoid valve error
10	EEPROM mutual memory Error
11	ODU fan motor error
12	ODU terminal board fuse error
13	Compressor rotation error
14	AC voltage error
17	Serial open circuit error
18	Serial short circuit error
19	Indoor unit fan error
20-4	EEPROM mutual memory Error
24-0	WLAN module communication error
24-1	WLAN router connection error
26	Indoor unit temperature thermistor error
	Appendix

Error Code 1	<h2 style="margin: 0;">Short circuit of ODU thermistor</h2>	1-0 Heat exchanger thermistor short-circuit(Orange) 1-1 Outside air temperature thermistor short-circuit(Green) 1-2 Suction thermistor short-circuit(Black) 1-3 For multi zone system: Gas pipe thermistor short-circuit(Brown,White,Blue) 1-3 For single zone system: 2-way valve thermistor short-circuit(Yellow) 1-4 Heat sink thermistor short-circuit 1-5 Discharge thermistor short-circuit error
--	---	---

☆ Check the thermistor short-circuit.

◇ Main cause

- The lead wire sheath of the ODU thermistor has been damaged due to edge or long-time friction by vibration, and the wire touches the pipe, etc.

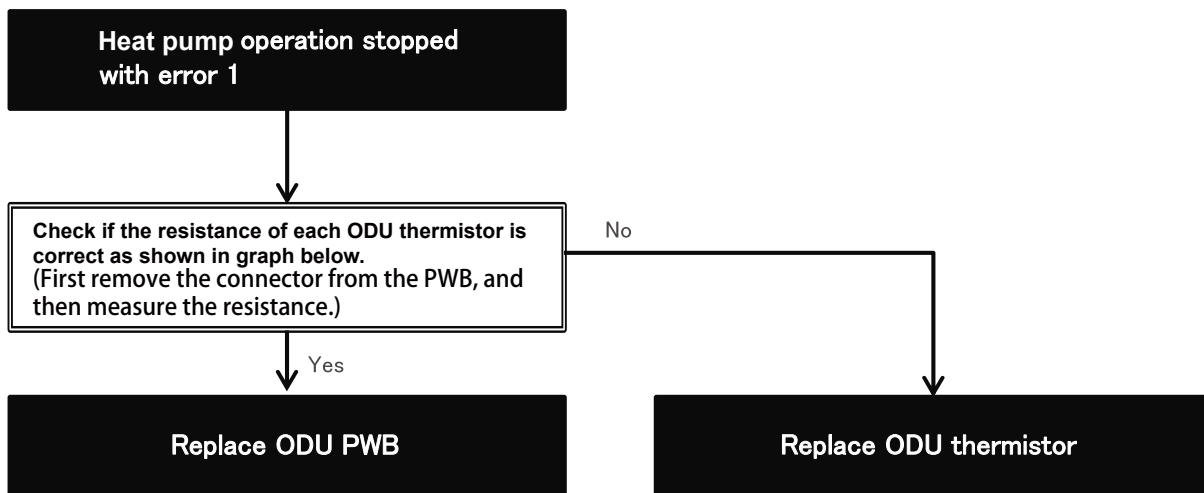

Please see Appendix ① (ODU thermistor R-T)

Error Code	2	Overheat error (Compressor or cycle)	2-0 Compressor high temperature error 2-1 Compressor discharge overheat 2-2 Outdoor unit pipe overheat 2-3 Indoor unit pipe overheat 2-5 IPM high temperature error
------------	---	--------------------------------------	---

☆ Check the failure of compressor

◇ Main cause

- Temperature of compressor or cycle parts becomes too high.

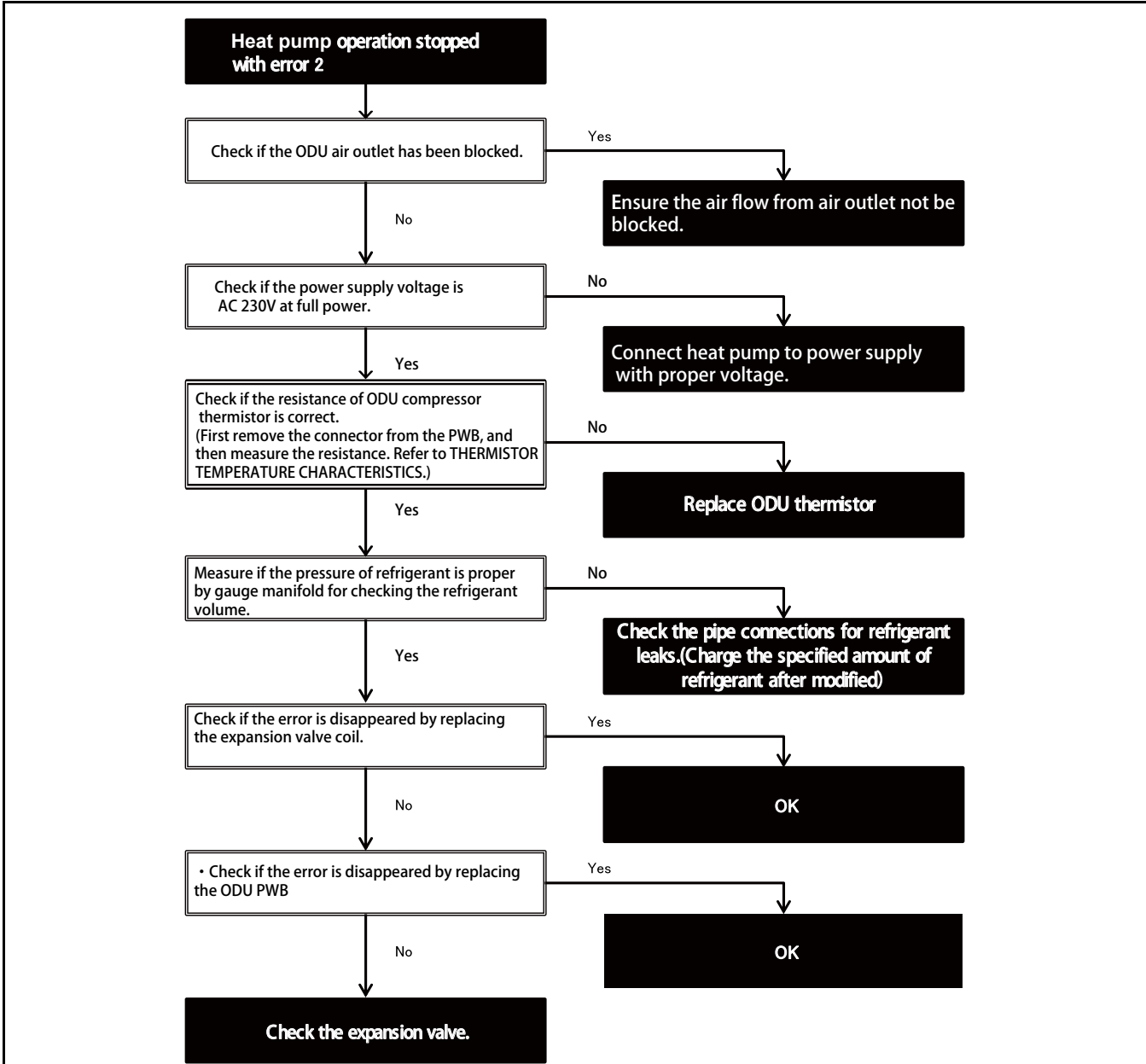

Please see Appendix ② (expansion valve check)

Error Code	5	Open circuit of ODU thermistor	5-0 Heat exchanger thermistor open-circuit(Orange)
5-1 Outside air temperature thermistor open-circuit(Green)			
5-2 Suction thermistor open-circuit(Black)			5-3 For multi zone system: Gas pipe thermistor open-circuit(Brown,White,Blue)
5-3 For single zone system: 2-way valve thermistor open-circuit(Yellow)			5-4 Compressor thermistor open-circuit(Red)
5-5 Heat sink thermistor open-circuit			

☆ Check the thermistor open-circuit.

◇ Main cause

- The lead wire of ODU thermistor has torn due to the edge or vibration.
- The attachment of connector has damaged by inside tension due to unsuitable wiring process.

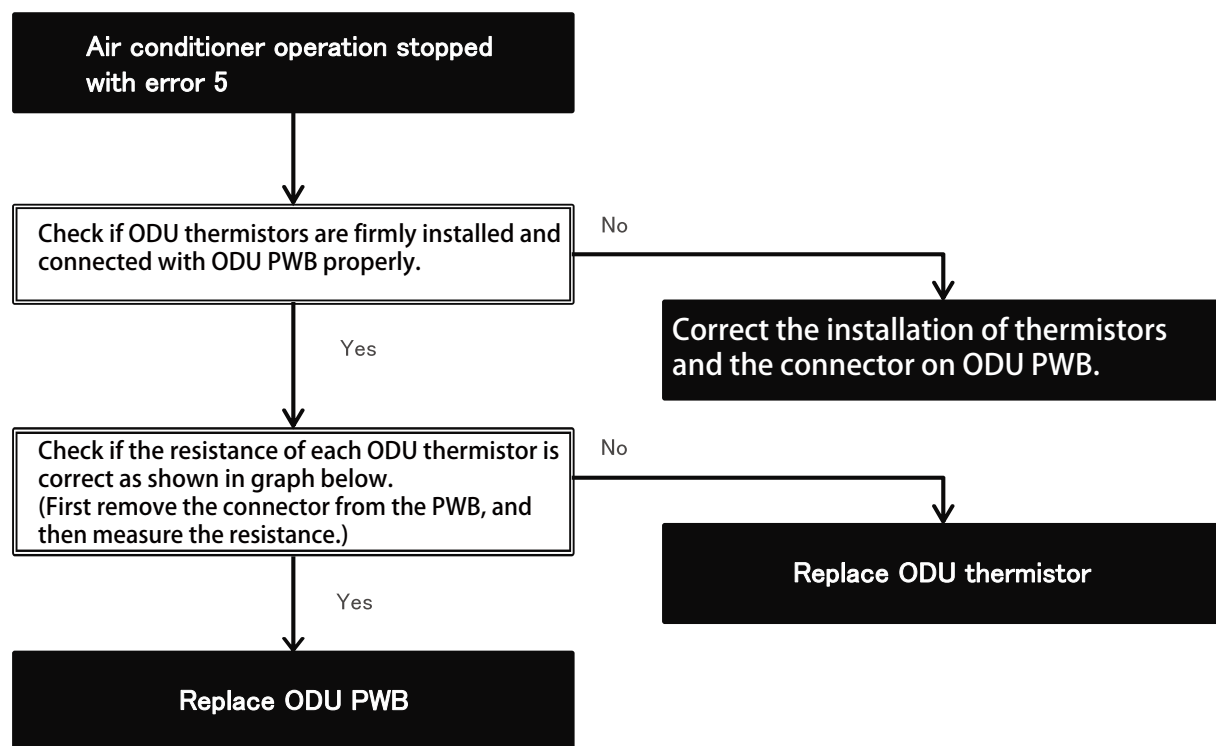

Please see Appendix ① (ODU thermistor R-T)

Error Code 6	<h2 style="margin: 0;">DC current error</h2>	6-0 DC current error 6-1 DC current error 1 6-2 DC current error 2 6-3 DC current error 3
---	--	--

☆ Check the cause due to compressor or PWB.

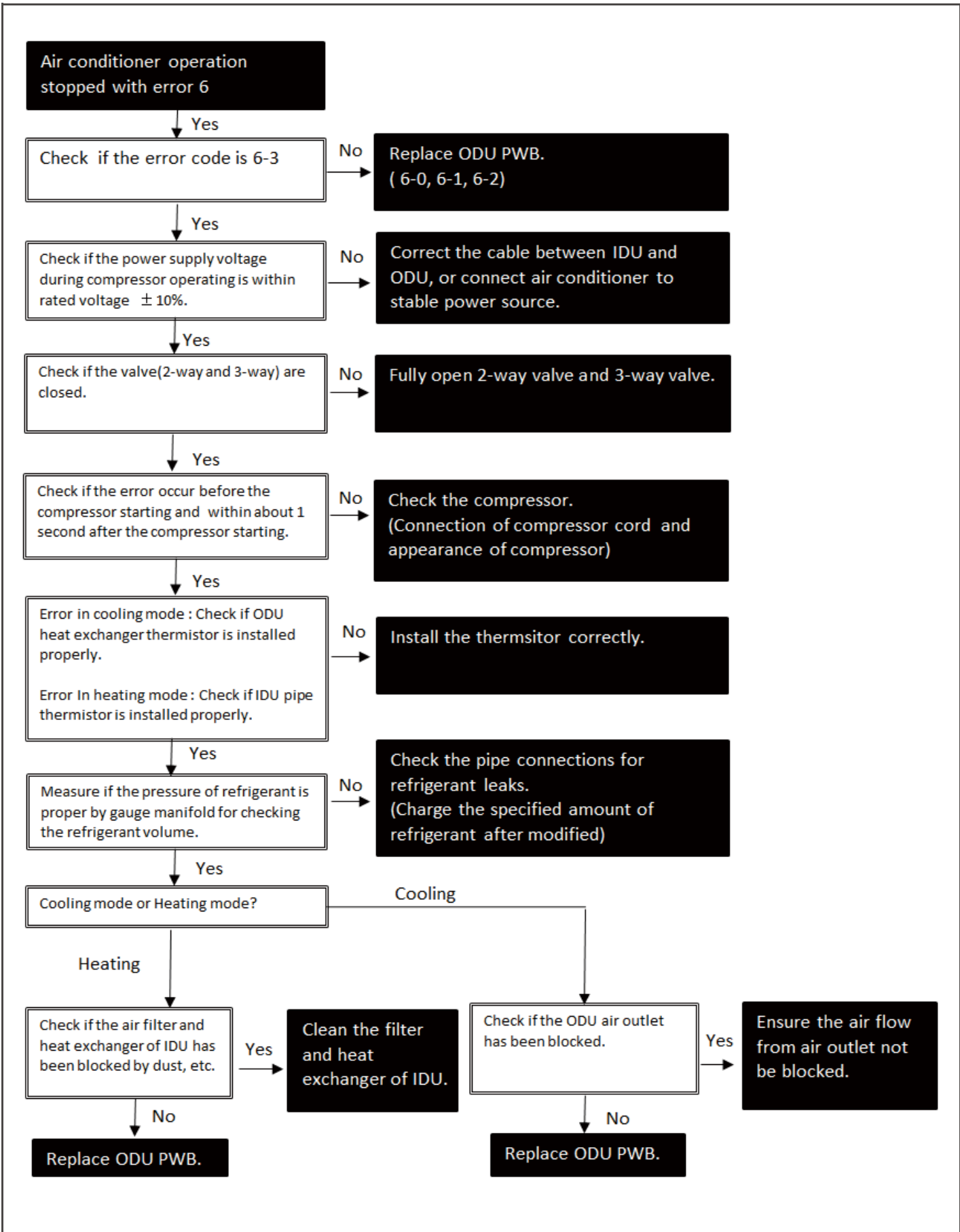

Error Code 7	<h2 style="margin: 0;">AC current error</h2>	7-0 AC over current error 7-1 AC current error when compressor OFF 7-2 AC maximum current error 7-3 AC current deficiency error
--	--	--

☆ Check the cause due to PWB or another parts.

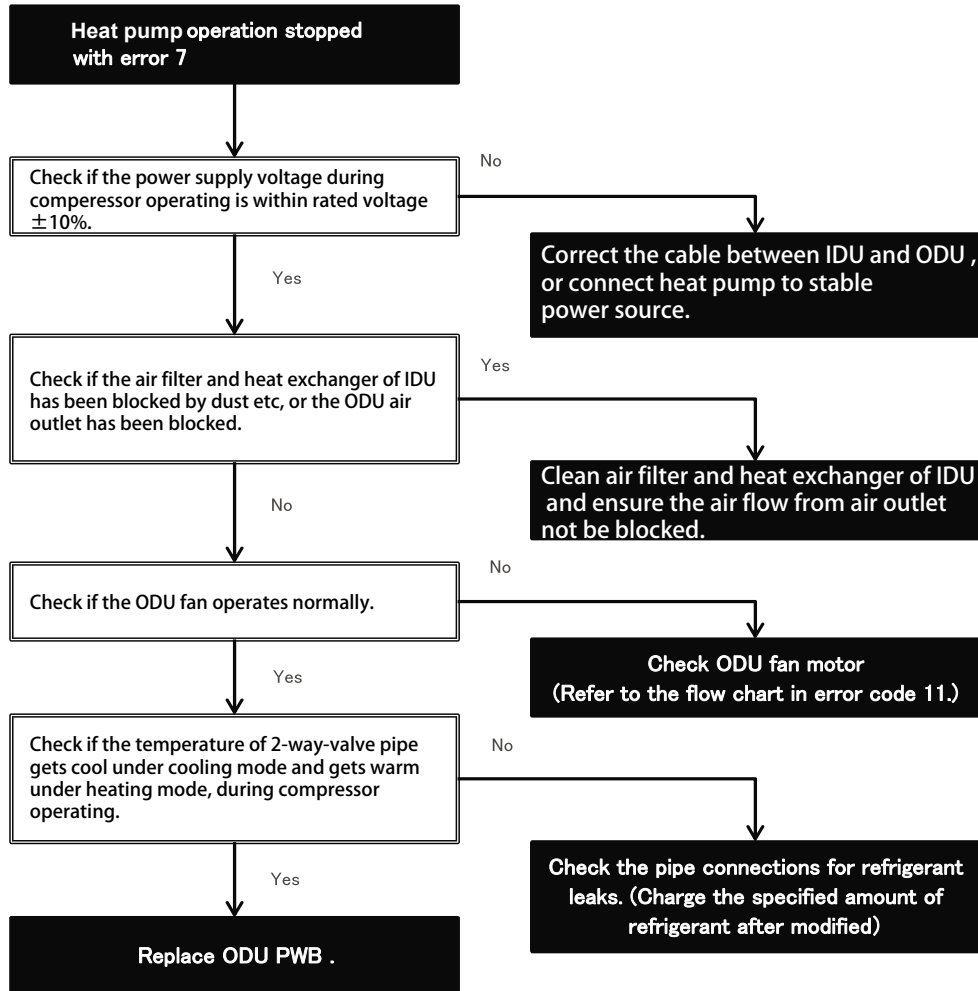

Error Code	9	Cycle error (1/3)	9-0 cycle temperature error 9-4 gas leak error
-------------------	----------	--------------------------	---

☆ Check the cause due to PWB or another parts.

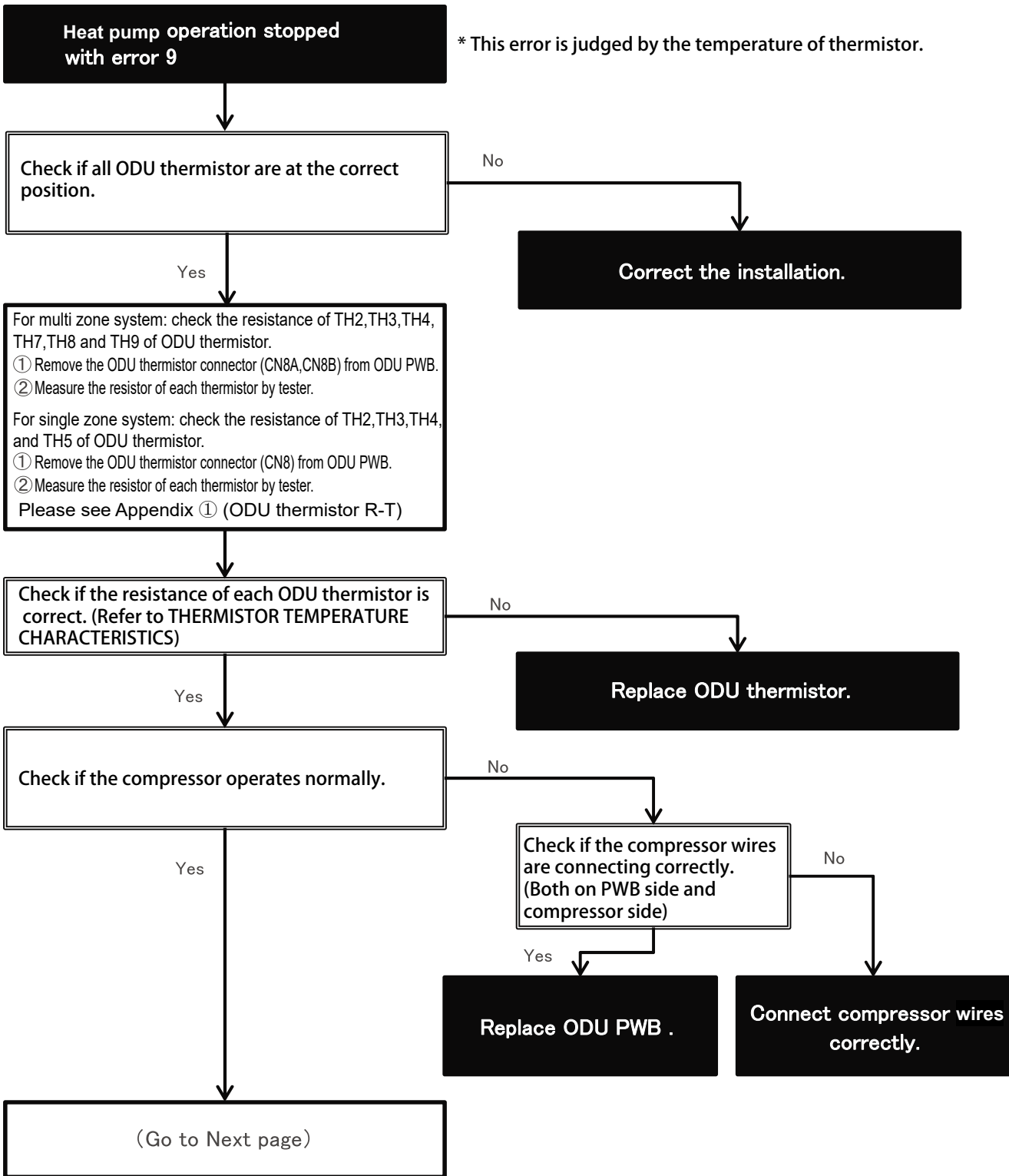

Error Code	Cycle error (2/3)	9-0 cycle temperature error 9-4 gas leak error
------------	-------------------	---

☆ Check the cause due to PWB or another parts.

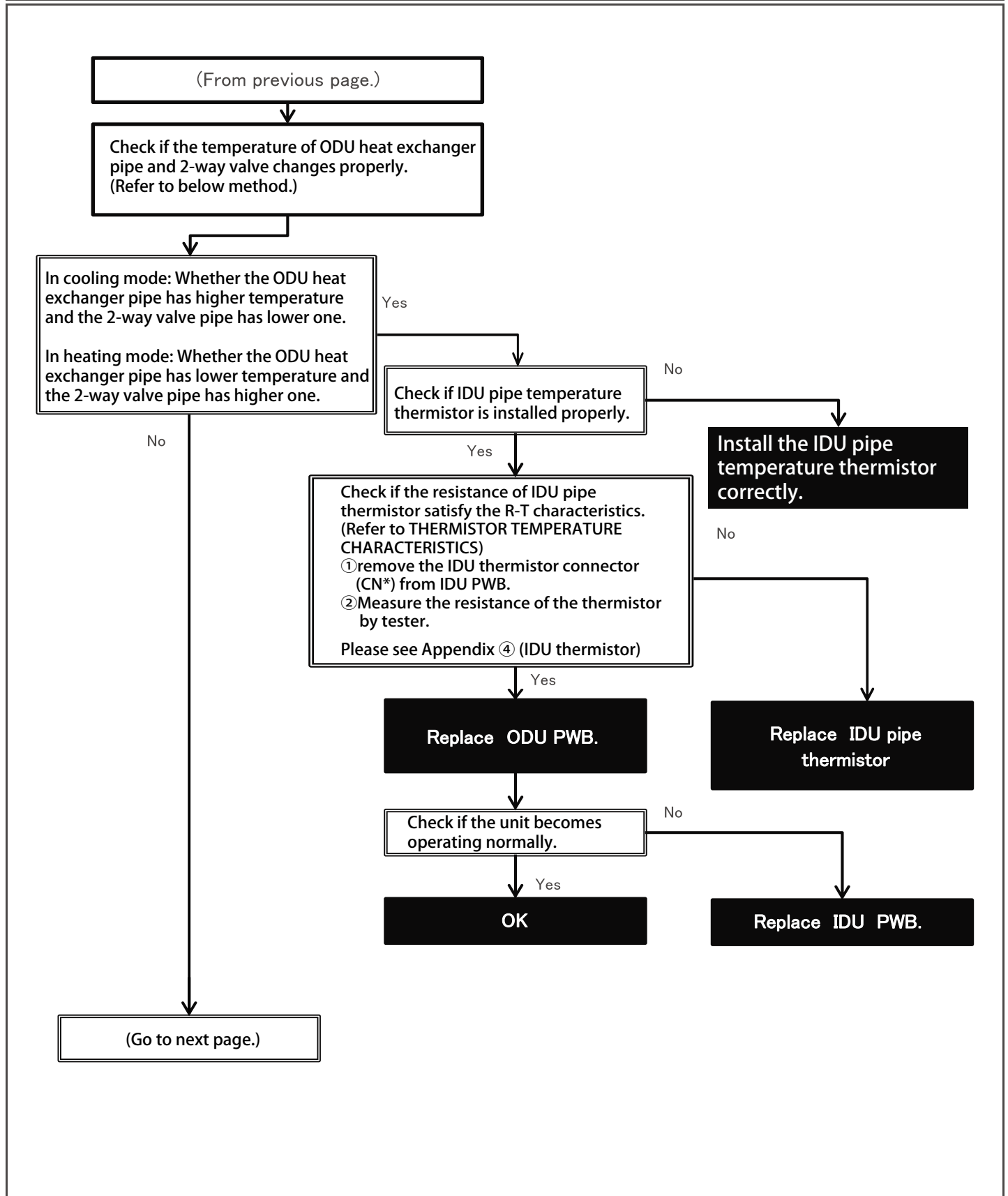

Error Code 9	Cycle error (3/3)	9-0 cycle temperature error 9-4 gas leak error
-------------------------------	--------------------------	---

☆ Check the cause due to PWB or another parts.

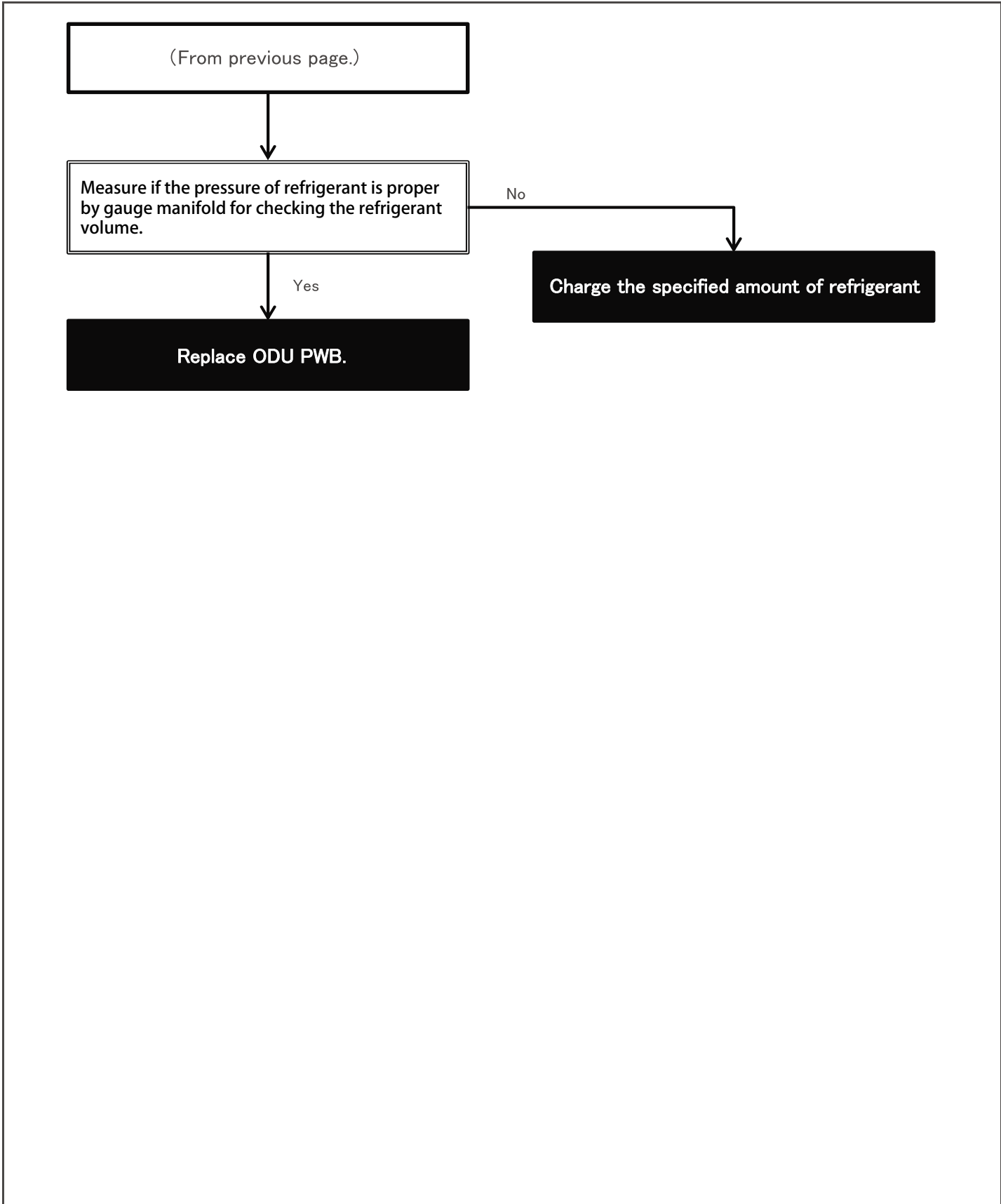

Error Code 9-5	2 way/ 3 way valve close error
--	--

☆ Check the cause Installation or other parts.

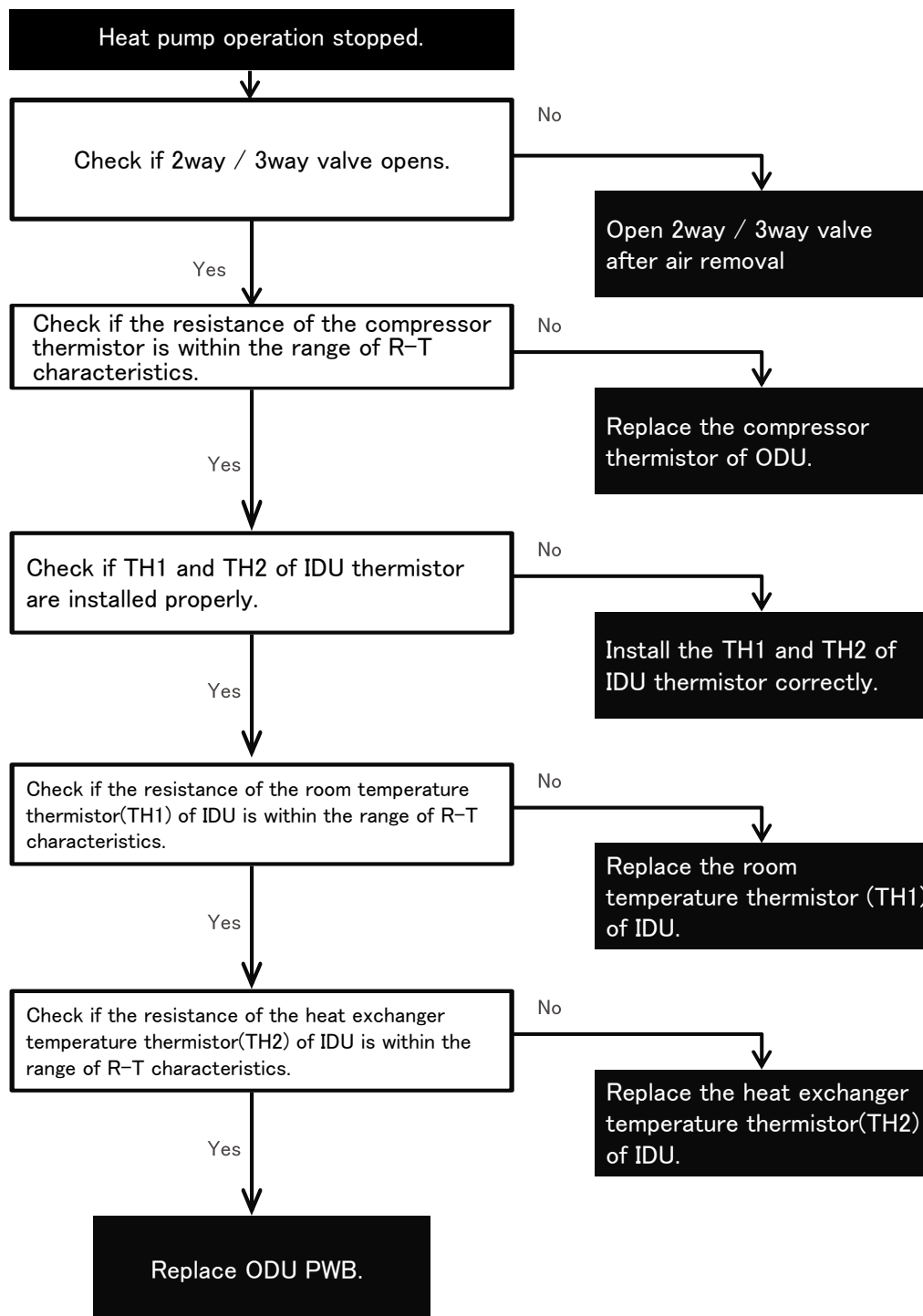

Error Code

9-6

Solenoid valve error(1/2)

9-6 solenoid valve error

☆ Check the cause due to PWB or another parts.

Heat pump operation stopped with error 9

* Error 9-6 refers to abnormal judgment using the temperature difference between the discharge thermistor and the solenoid valve thermistor, or the temperature rise of HP.

Check the resistance of TH1 and TH10 of ODU thermistor.
 ① Remove the ODU thermistor connector(CN8A,CN8B) from ODU PWB.
 ② Measure the resistance of each thermistor by tester.
 Please see Appendix ① (ODU thermistor R-T)

Check if the resistance of each ODU thermistor is within the range of R-T characteristics.

Replace ODU thermistor.

Check if TH1 and TH10 of ODU thermistor are installed properly.

Install the ODU thermistor correctly.

Check if the compressor operating normally.

(Go to next page.)

Check if the compressor wires are connecting correctly. (Both on PWB side and compressor side)

Replace ODU PWB .

Connect compressor wires correctly.

Error Code

9-6

Solenoid valve error(2/2)

9-6 solenoid valve error

☆ Check the cause due to PWB or another parts.

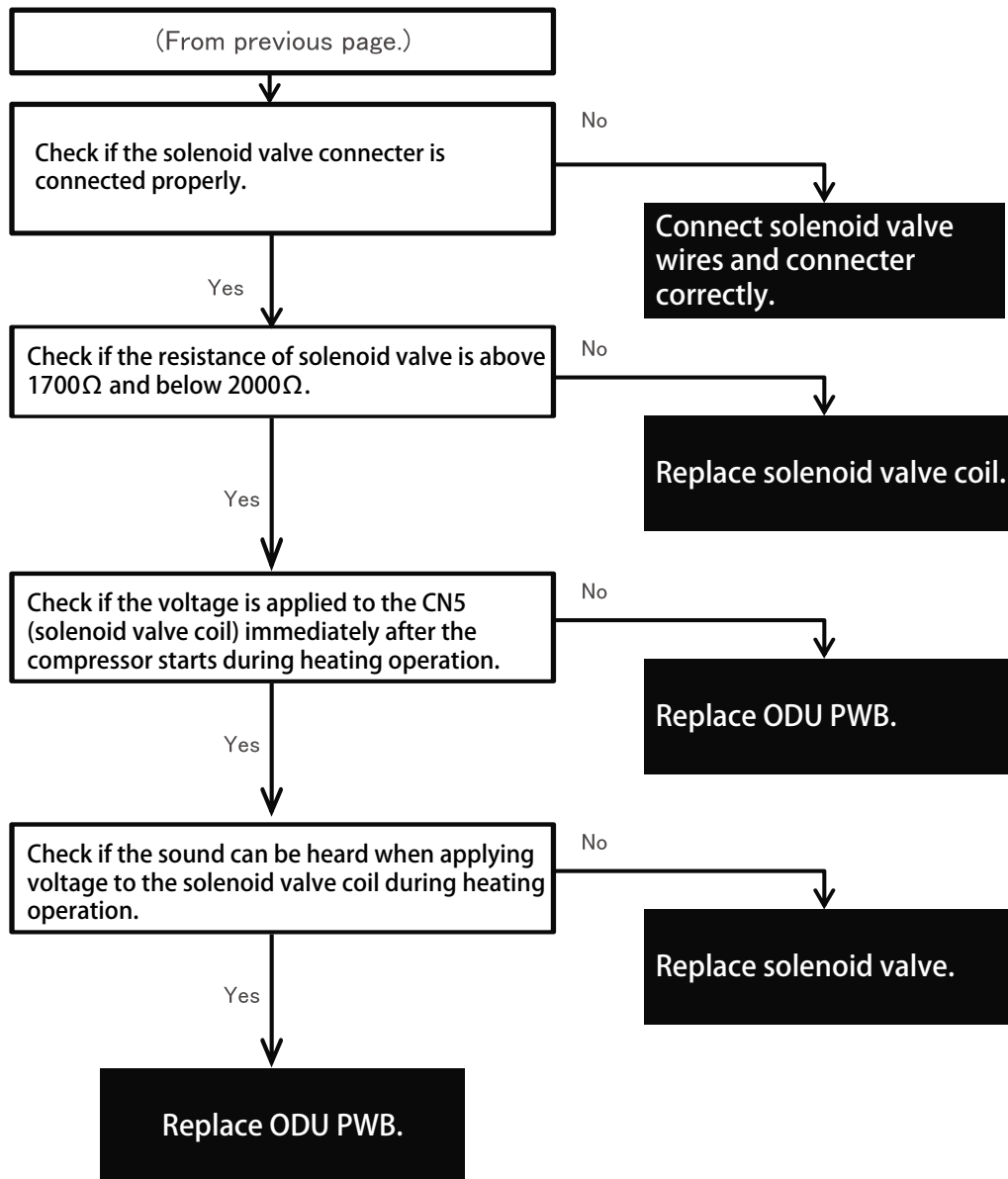

Error Code 10	EEPROM mutual memory Error	10-4 EEPROM Mutual memory error 10-5 EEPROM Mutual memory error (data error 2)
--------------------------------	-----------------------------------	---

☆ Identify whether the cause is outdoor unit data error or indoor unit data error.

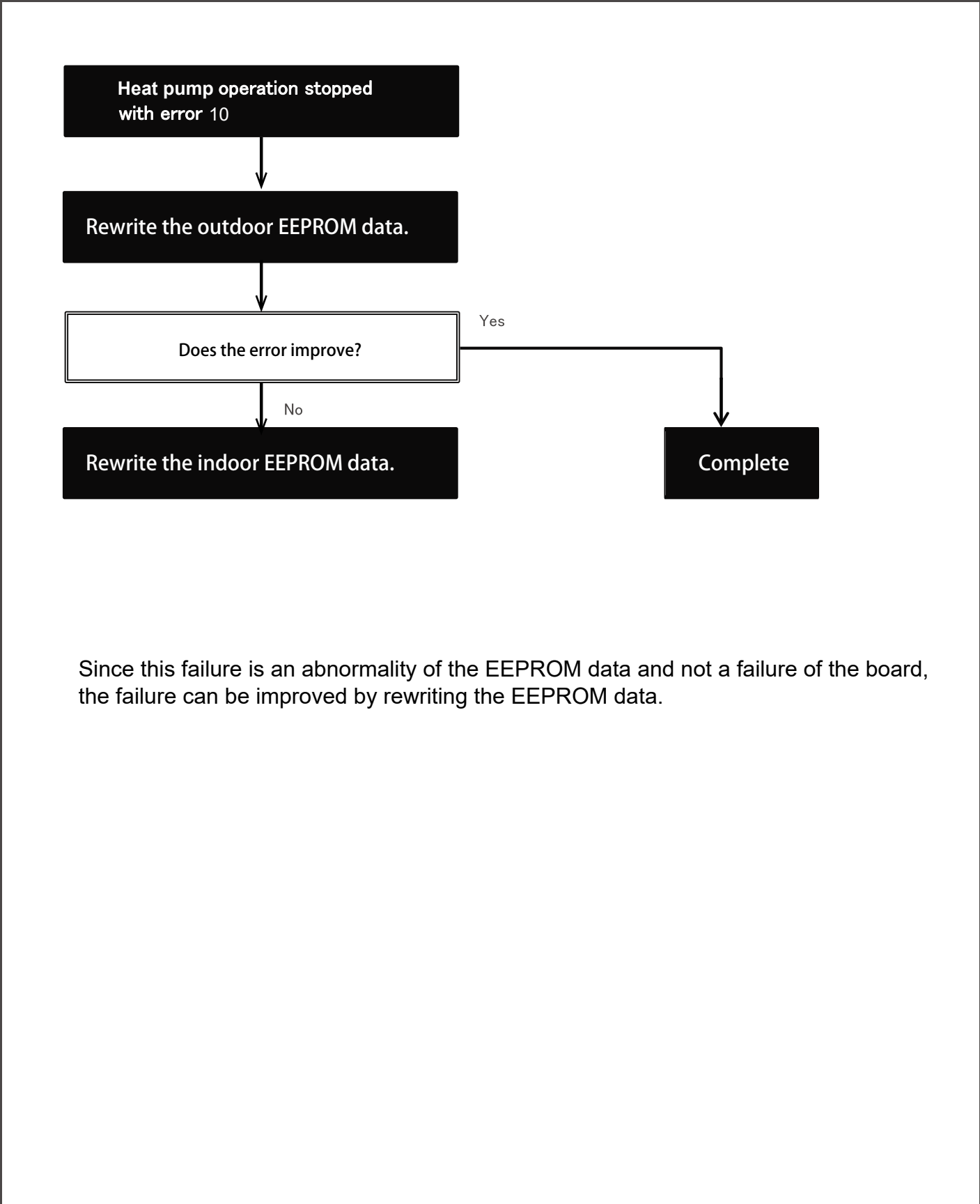

Since this failure is an abnormality of the EEPROM data and not a failure of the board, the failure can be improved by rewriting the EEPROM data.

Error Code	<h1>ODU fan motor error</h1>	11-1 DC fan driver IC error 11-2 DC fan lock error 11-3 Detection error of negative rotation before compressor start 11-4 Detection error of inverter current 11-5 open connector error
------------	------------------------------	---

☆ Check the cause due to PWB or DC fan motor.

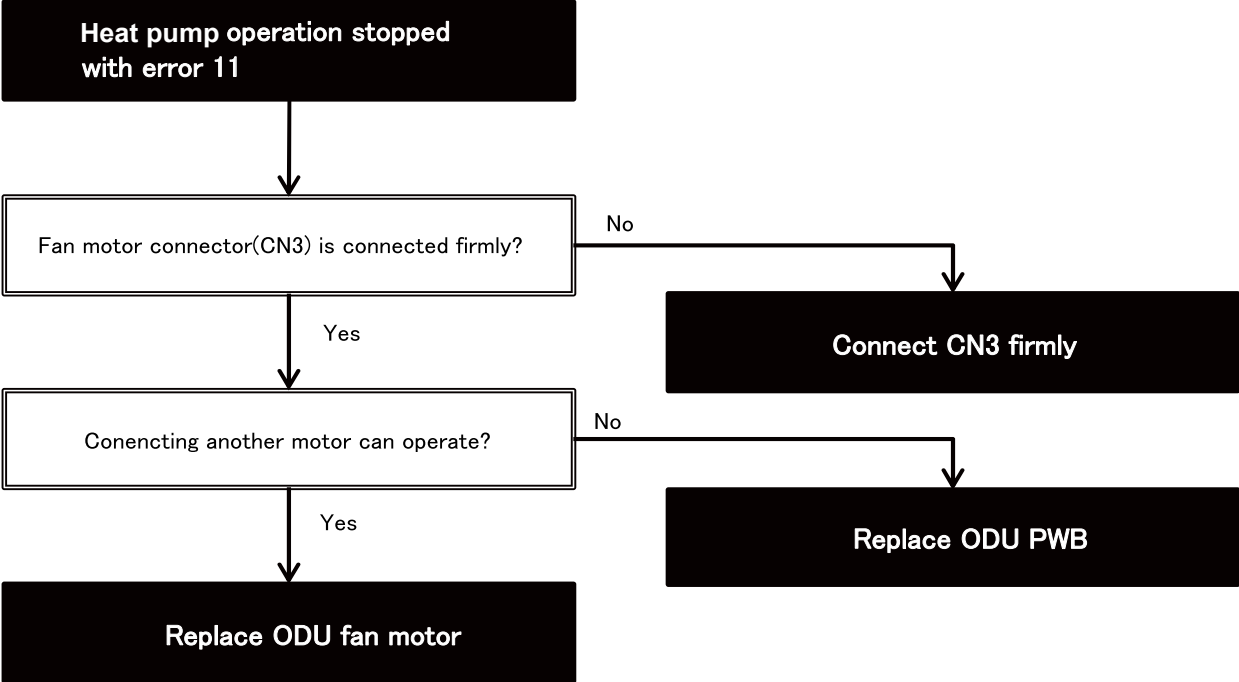

Error Code 12	ODU terminal board fuse error	12-0 ODU terminal board thermal fuse error
--------------------------------	--------------------------------------	--

☆ Check the thermal fuse open-circuit in terminal board.

◇ Main cause

- The lead wire(CN2) from terminal board has broken due to the edge or vibration.
- The attachment of connecetor from terminal board has broken by inside tension due to unsuitable wiring process.
- The thermal fuse in the ODU terminal board blown due to poor connection of wiring on terminal board.

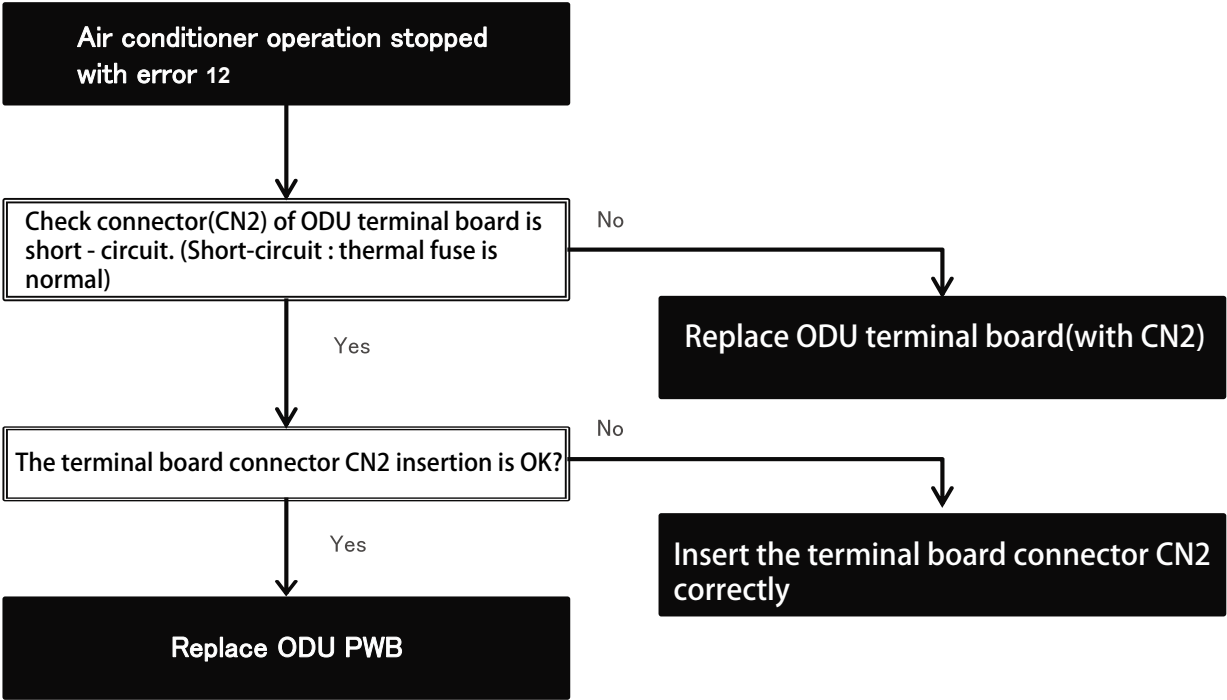

Error Code	13 Compressor rotation error	13-0 compressor motor short error 13-1 compressor motor open or PWB short error 13-2 compressor motor lock error
------------	-------------------------------------	--

☆ Check the cause due to compressor.

◇ Main Cause

- Compressor motor winding has abnormality. (Short or open)
- PWB has abnormality. (IPM Shunt resistor is short)

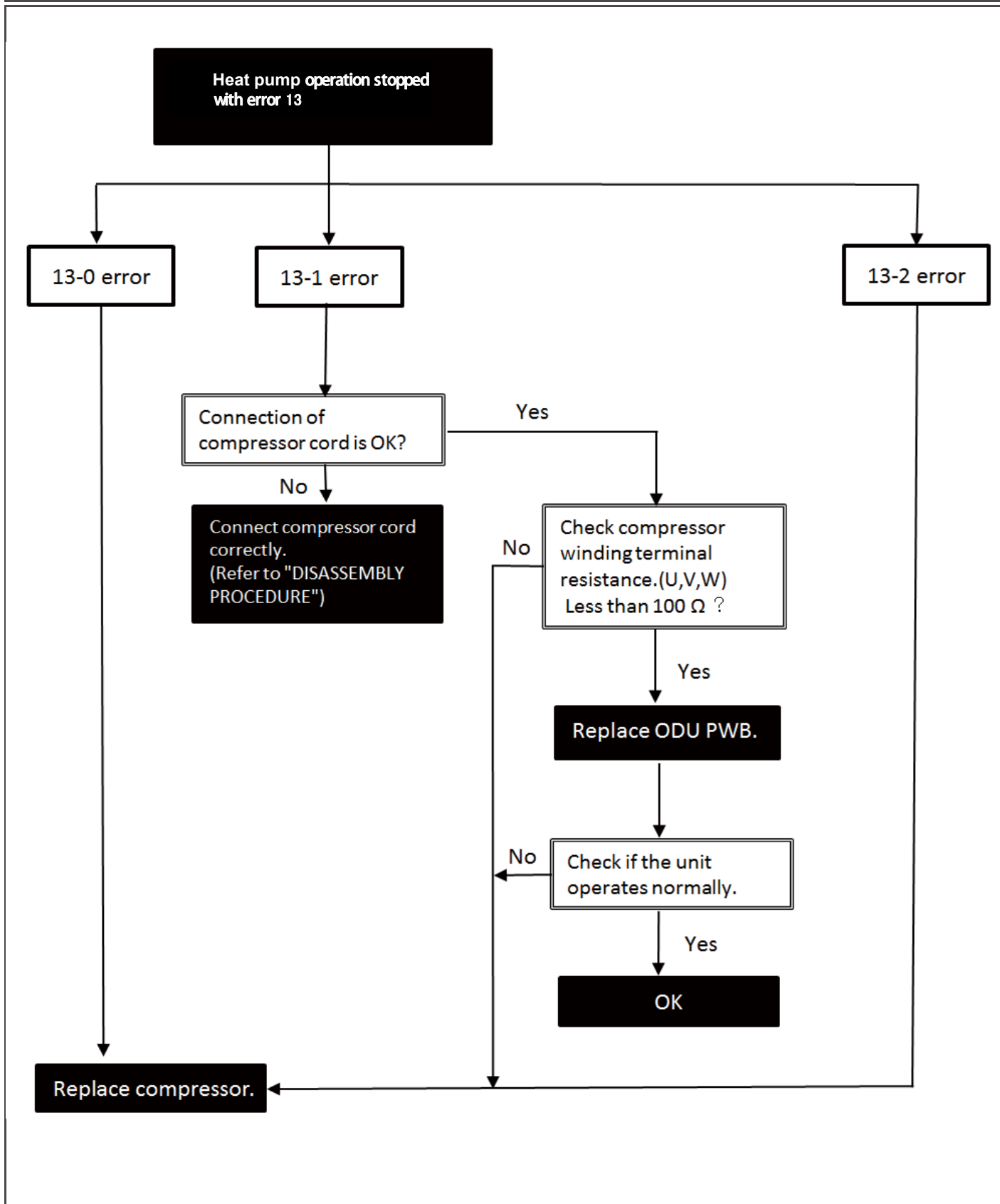

Error Code 14	AC voltage error	14-0 over voltage error 14-1 clock error 14-2 Abnormal AC power supply voltage or DC low voltage error
------------------------------------	-------------------------	--

☆ Check AC power supply.

- ◇ Main cause
- AC power supply voltage is abnormal. (Not within rated voltage $\pm 10\%$)
 - Big fluctuation of AC power supply voltage
 - Instantaneous voltage drop

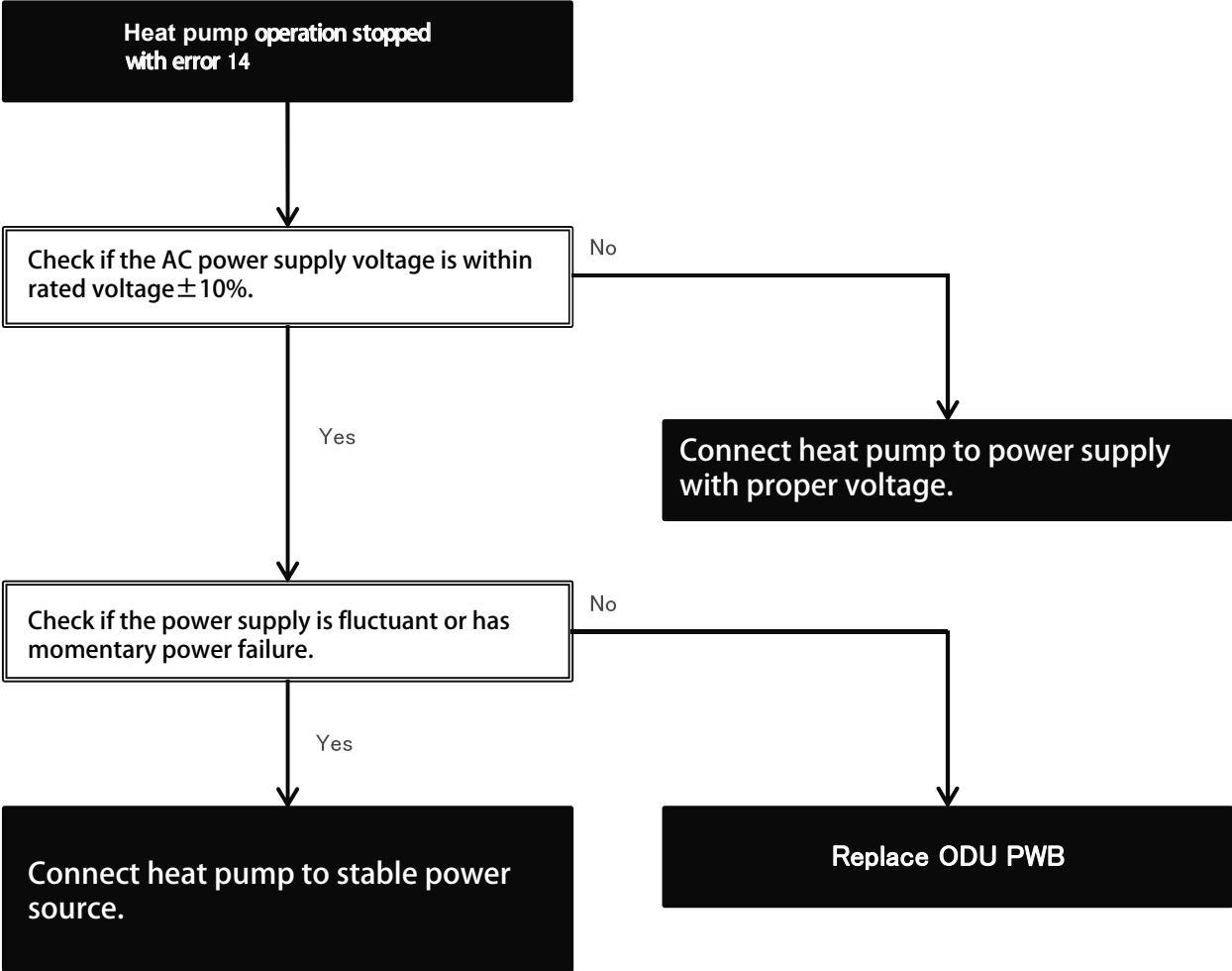

Error Code	<h1>17</h1>	<h2>Serial open error (1/2)</h2>	17-0 Serial open error
------------	-------------	----------------------------------	------------------------

☆ Determine why serial communication is not possible.

- Defective PWB of IDU (Serial circuit failure, power supply circuit operation failure, etc.)
- Defective PWB of ODU (Serial circuit failure, power supply circuit operation failure, etc.)
- Poor connection of the wiring between the units connecting the IDU and the ODU
- Defective terminal board of IDU.
- Poor connection of electrical components mounted other than the PWB (outdoor unit reactor, etc.)

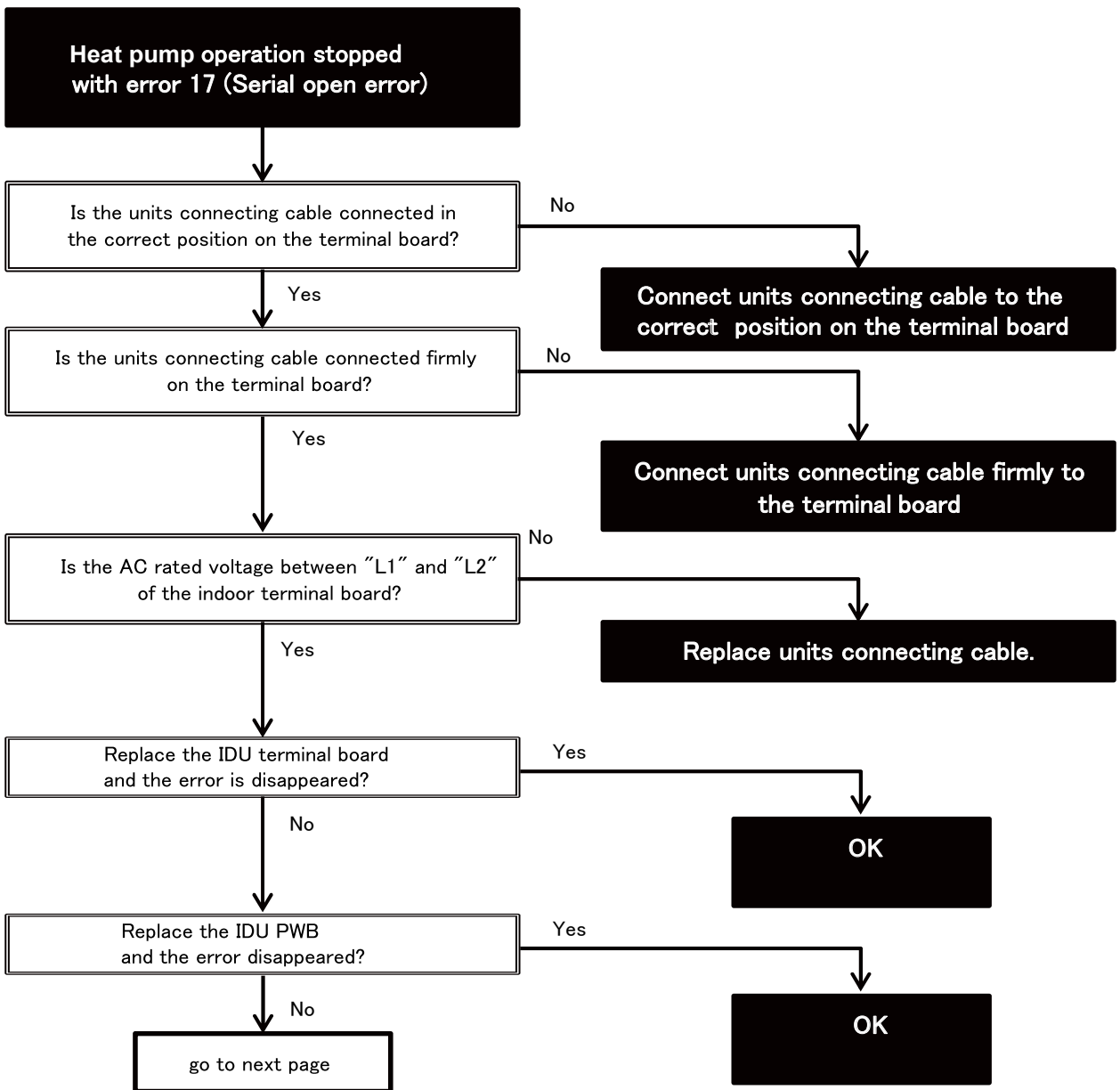

Error Code 17	Serial open error(2/2)	17-0 Serial open error
--------------------------------	-------------------------------	------------------------

☆Determine why serial communication is not possible.

- Defective PWB of IDU (Serial circuit failure, power supply circuit operation failure, etc.)
- Defective PWB of ODU (Serial circuit failure, power supply circuit operation failure, etc.)
- Poor connection of the wiring between the units connecting the IDU and the ODU
- Defective terminal board of IDU.
- Poor connection of electrical components mounted other than the PWB (outdoor unit reactor, etc.)

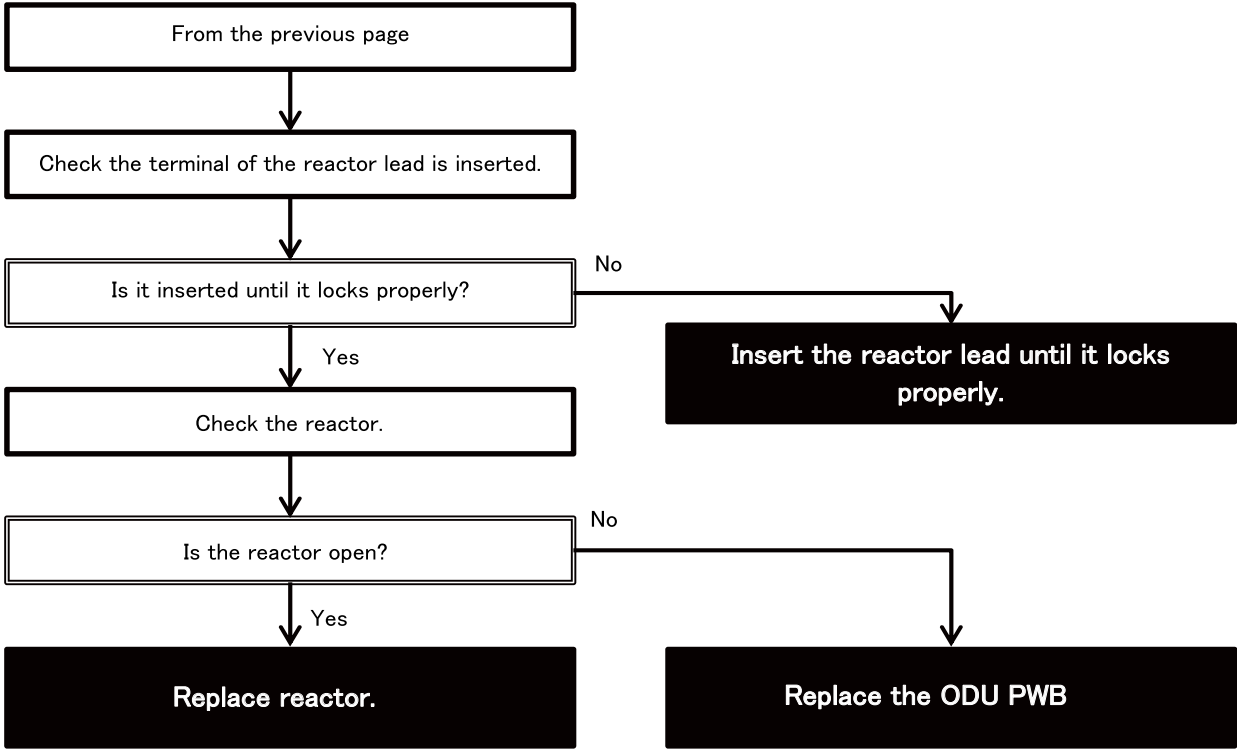

Error Code	<h2>Serial short error</h2>	18-0 Serial short 18-1 Incorrect wiring 18-2 High speed serial error
18		

☆ Determine if the units connecting cable is incorrectly inserted or the control board is defective.

◇ Main causes of serial shorts

- Incorrect insertion of units connecting cable
- Indoor unit serial circuit failure
- Outdoor unit serial circuit failure

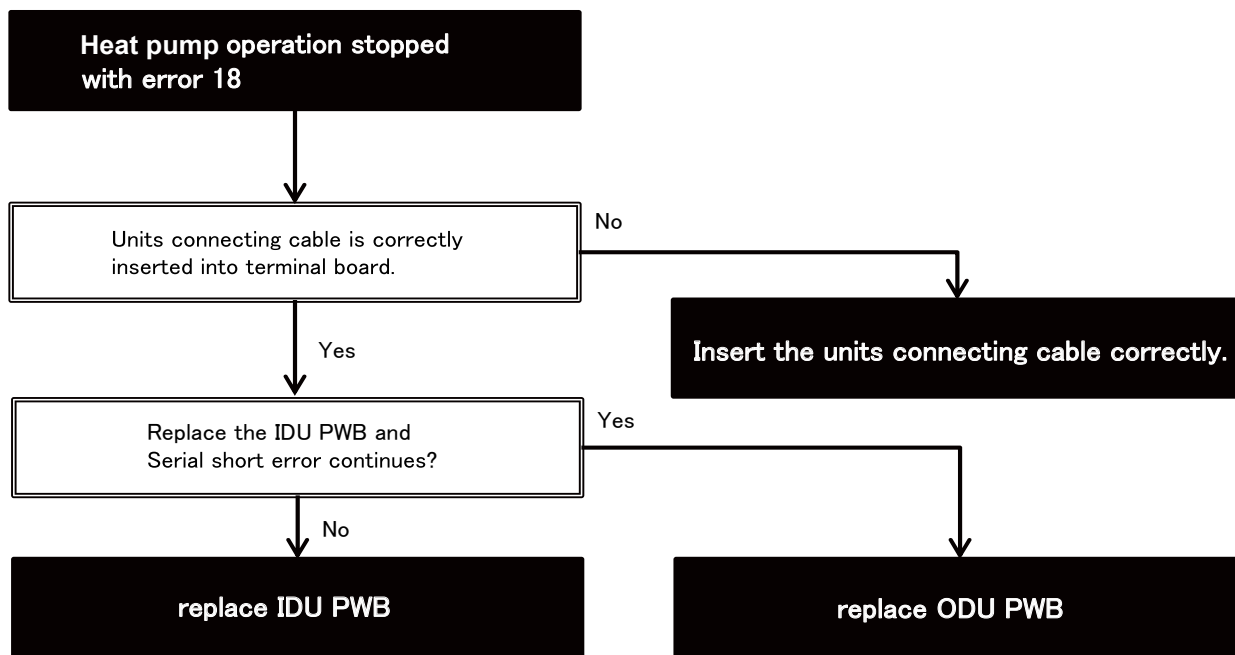

Error Code 19	Indoor fan error	19-0 Indoor fan error
------------------------------------	-------------------------	-----------------------

☆ Determine whether the cause is the indoor fan motor or the IDU PWB.

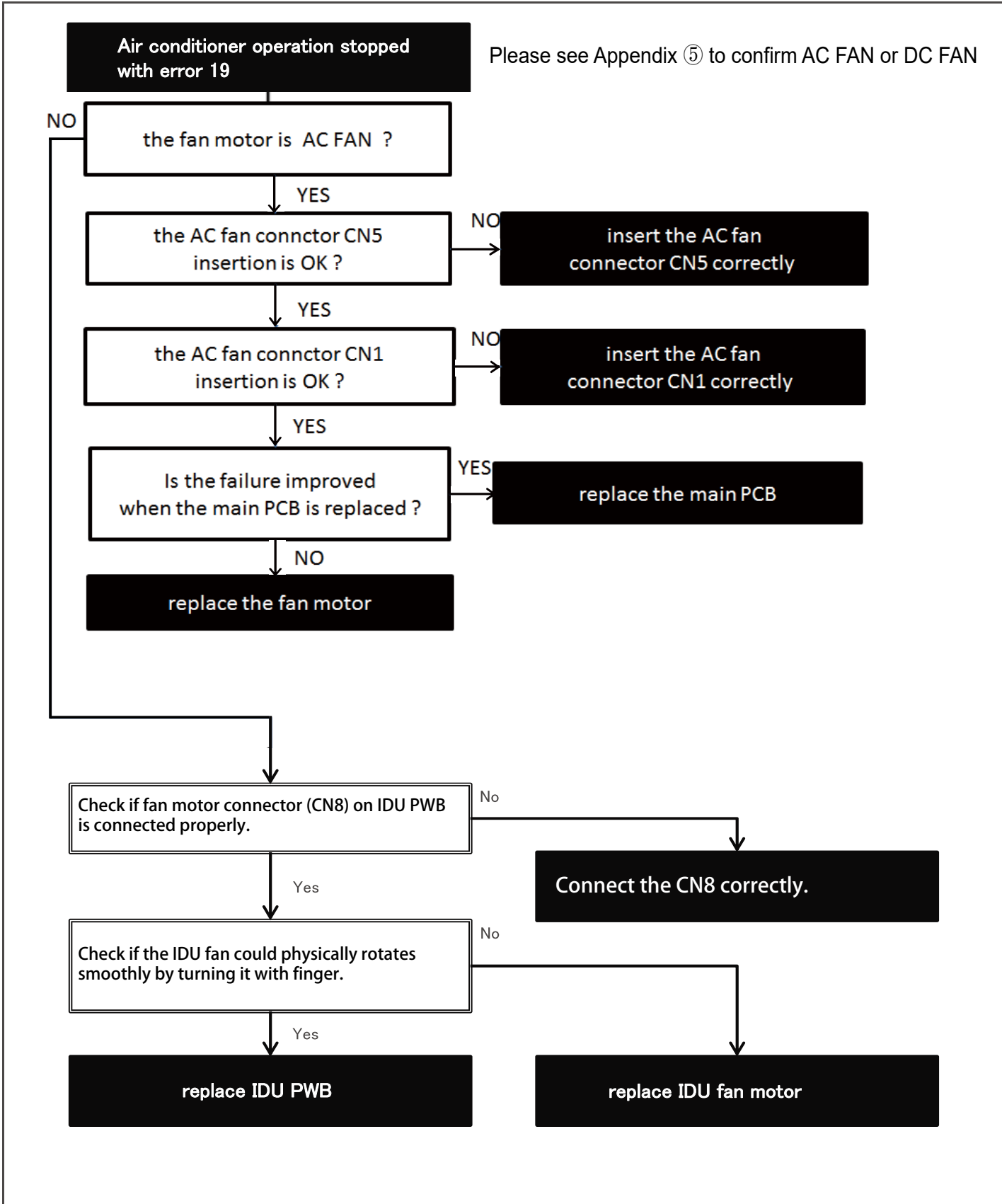

Error Code

20-4**EEPROM mutual memory Error**

☆ Identify whether the cause is outdoor unit data error or indoor unit data error.

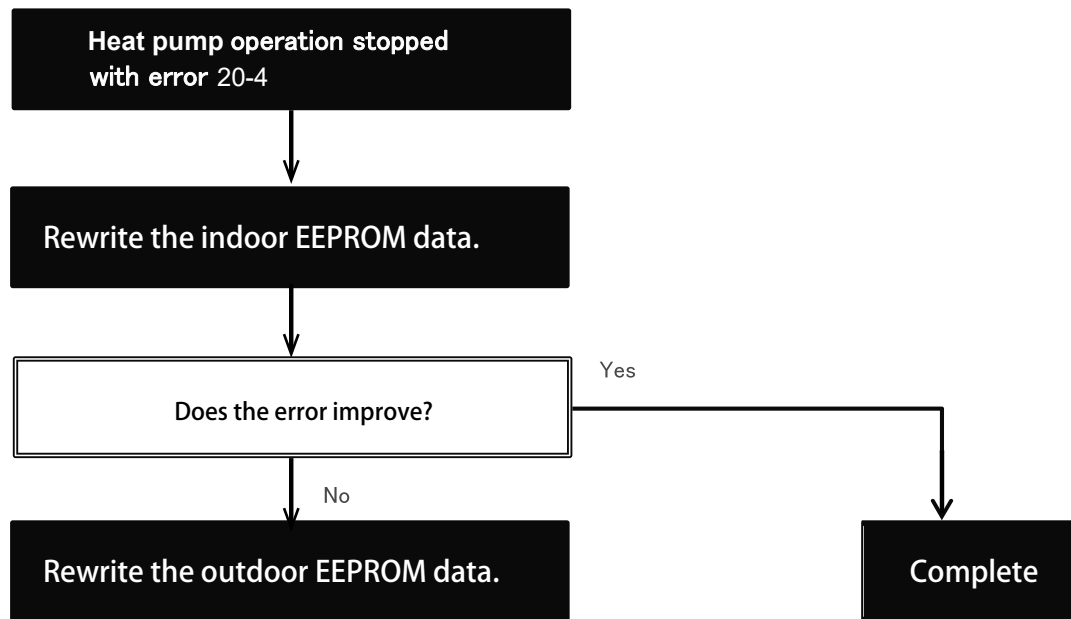

Since this failure is an abnormality of the EEPROM data and not a failure of the board, the failure can be improved by rewriting the EEPROM data.

Error Code 24-0	WLAN module communication error	
----------------------------------	--	--

☆Determine whether the cause is a connector or a board (WLAN module, main board).

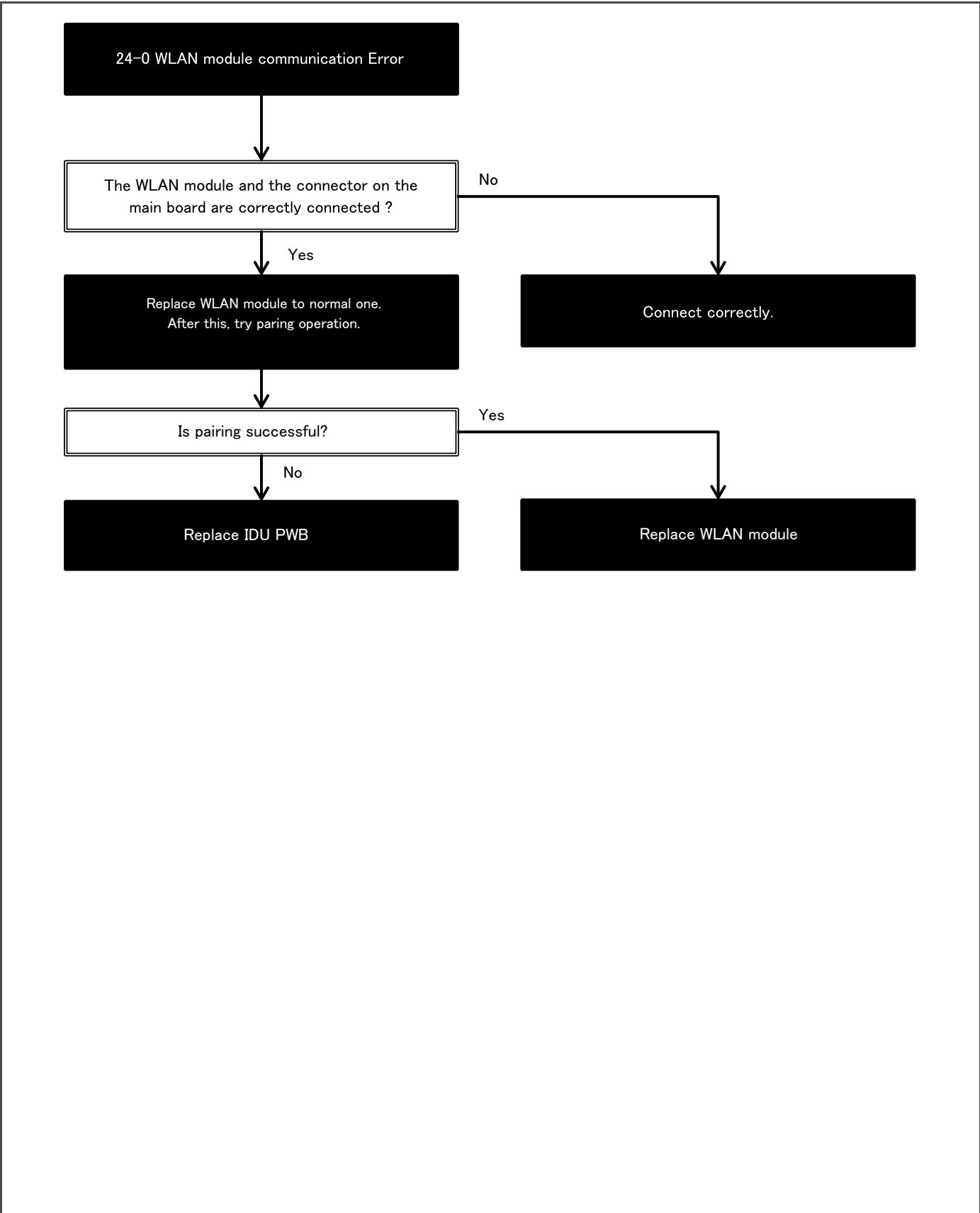

Error Code

24-1

WLAN router connection error

☆ Determine whether the cause is a WLAN module or a WLAN router.

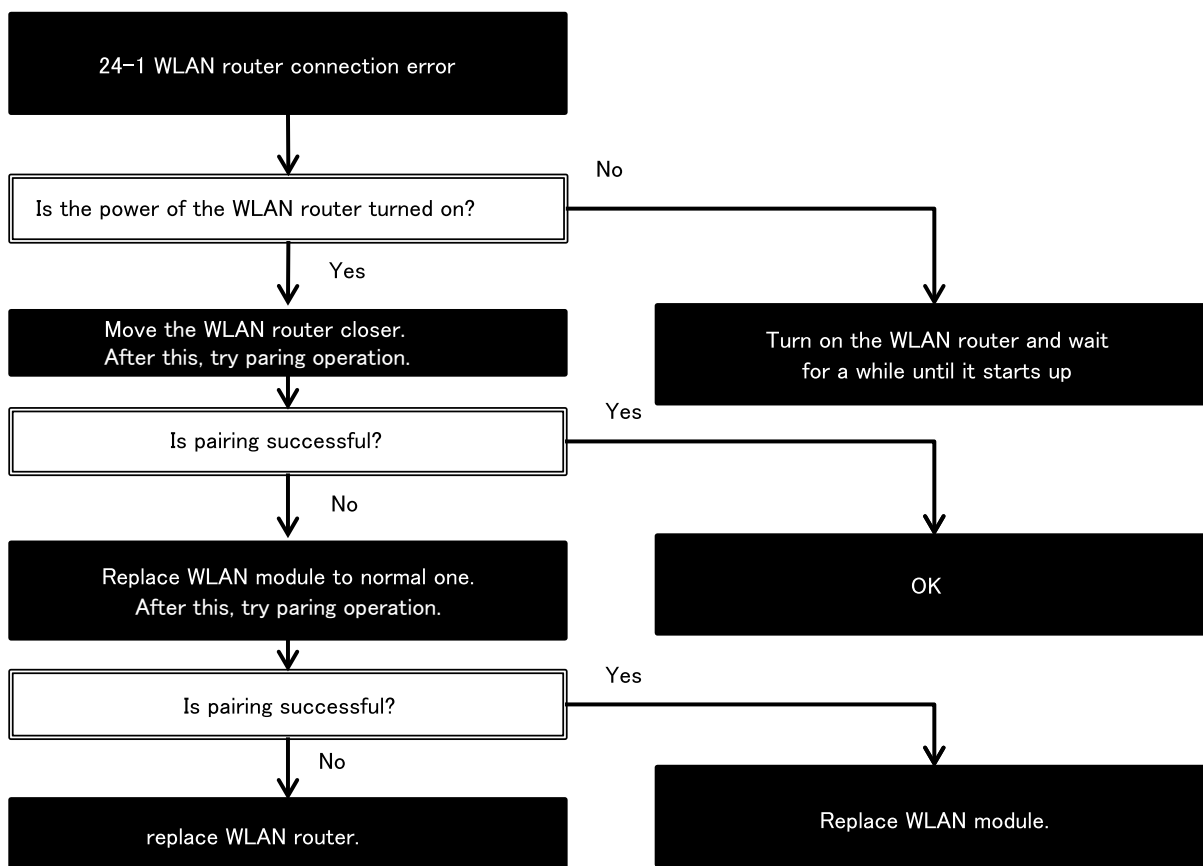

Error Code 26	Indoor unit temperature thermistor error	26-1 Room temperature thermistor error 26-2 Heat exchanger thermistor error 26-3 Liquid pipe thermistor
--------------------------------	---	---

☆ Determine whether the cause is room temperature/heat exchanger/liquid pipe thermistor or IDU PWB.

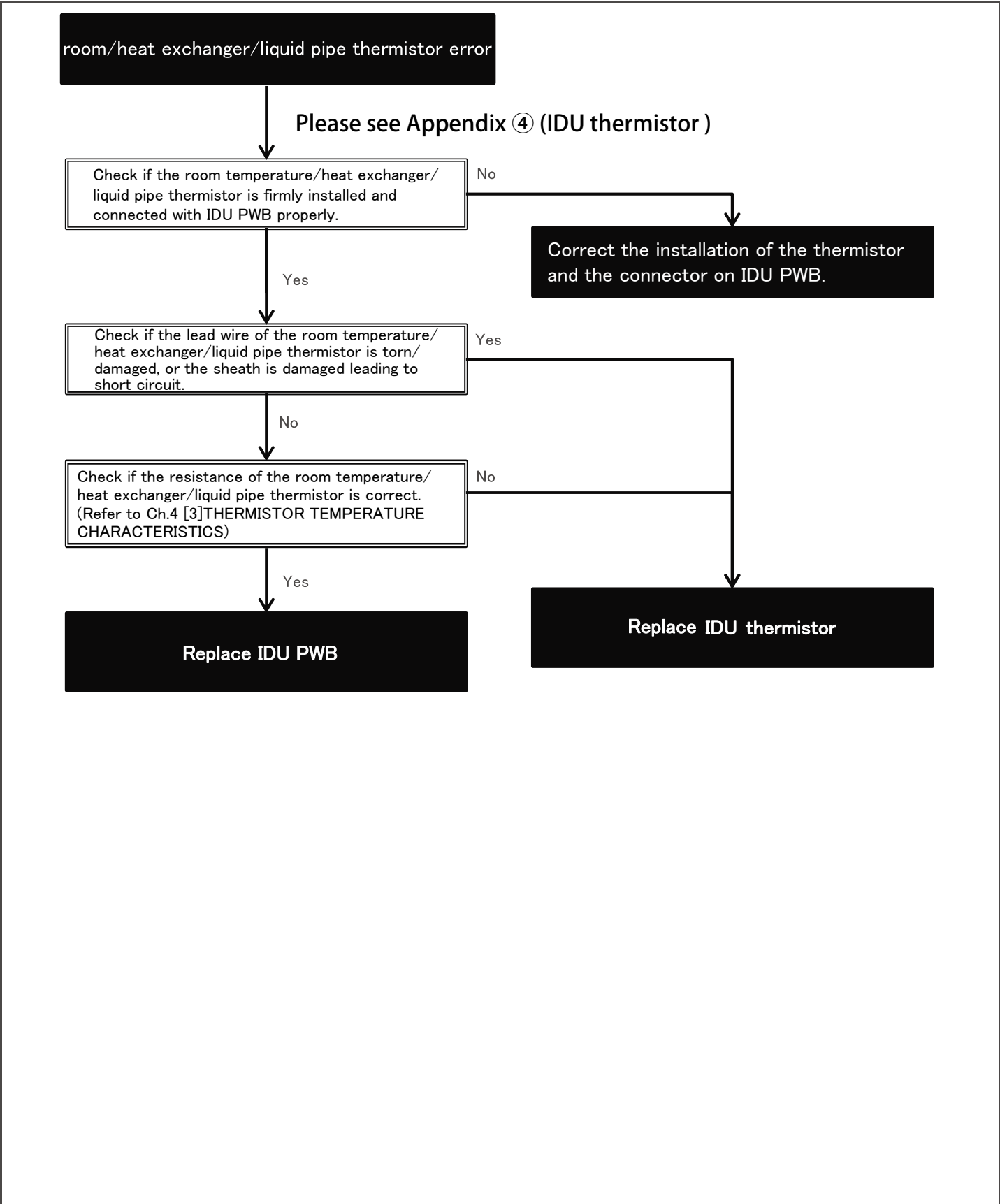

APPENDIX

① ODU thermistor

Temperature properties of outdoor thermistors

- TH1 : Compressor thermistor (CN8A ① - ②)
- TH2 : Heat exchanger pipe thermistor (CN8A ③ - ④)
- TH3 : Outdoor temp. thermistor (CN8A ⑤ - ⑥)
- TH4 : Suction thermistor (CN8A ⑦ - ⑧)
- TH7 : Thermistor unit A (CN8B ① - ②)
- TH8 : Thermistor unit B (CN8B ③ - ④)
- TH9 : Thermistor unit C (CN8B ⑤ - ⑥)
- TH10 : Solenoid Valve (CN8B ⑦ - ⑧)

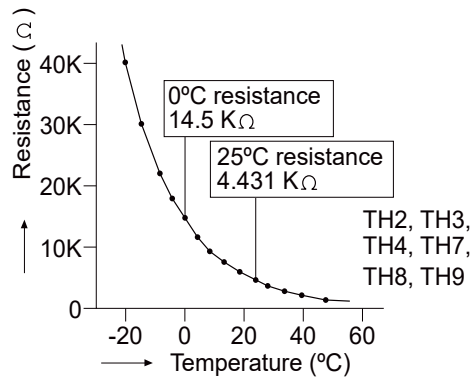
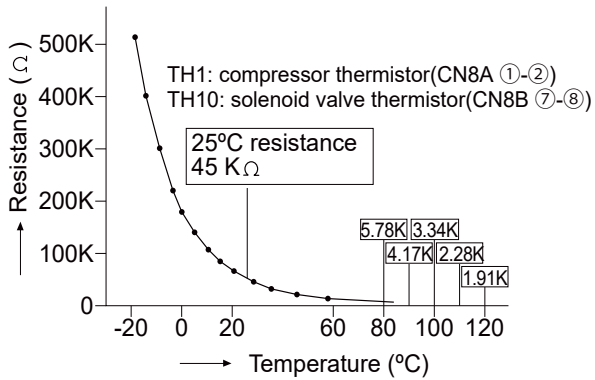
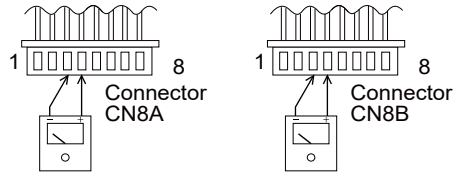

Thermistor	No.	Connector	Color	Connector pin
Compressor thermistor	TH1	CN8A	Red	No. 1 to 2
Heat exchanger pipe thermistor	TH2	CN8A	Orange	No. 3 to 4
Outdoor temp. thermistor	TH3	CN8A	Green	No. 5 to 6
Suction thermistor	TH4	CN8A	Black	No. 7 to 8
Thermistor unit A (suction)	TH7	CN8B	Blue	No. 1 to 2
Thermistor unit B (suction)	TH8	CN8B	White	No. 3 to 4
Thermistor unit C (suction)	TH9	CN8B	Brown	No. 5 to 6
Solenoid Valve thermistor	TH10	CN8B	Yellow	No. 7 to 8

② Expansion valve check

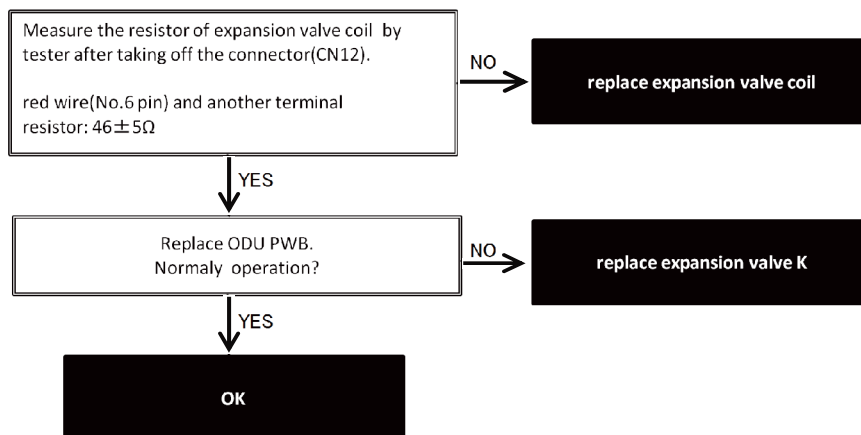

APPENDIX

③ Compressor check

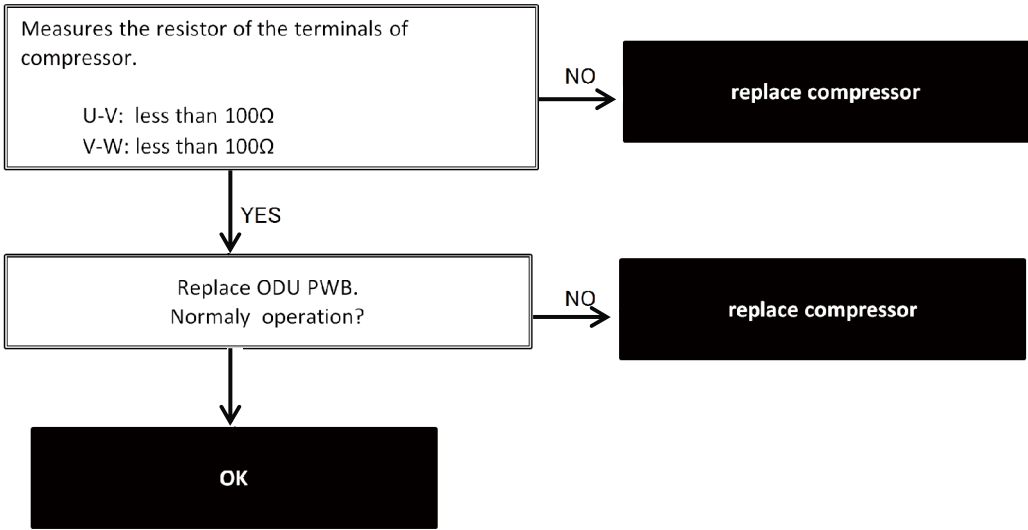

④ IDU thermistor

To measure the resistance, first remove the connector from the board.

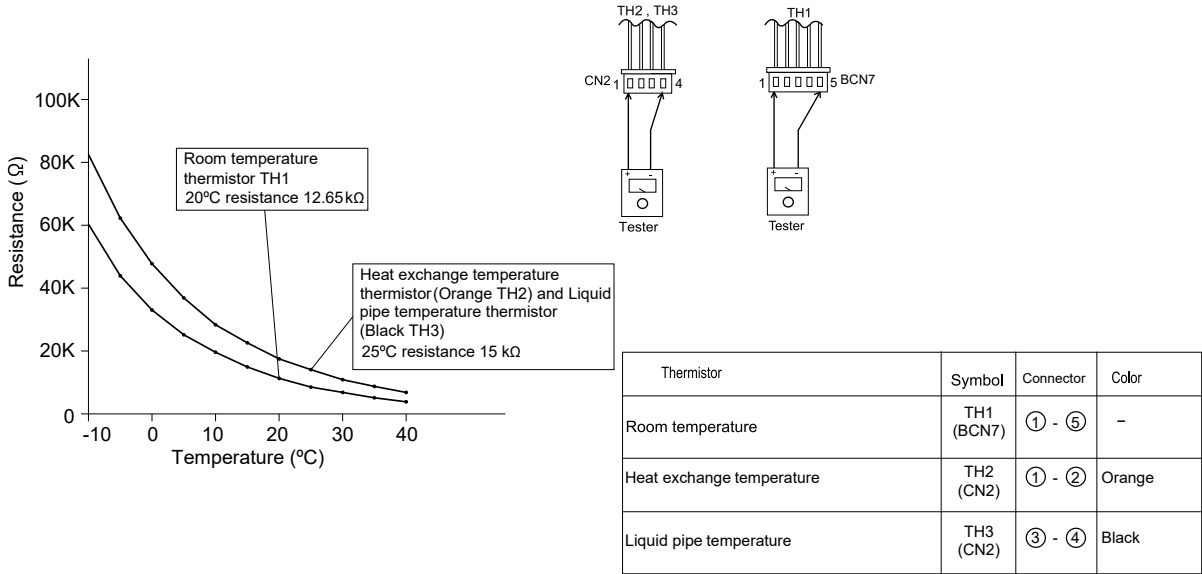

Before measuring resistance, disconnect connectors as shown above

⑤ Indoor fan

AY-XPC9CU	DC FAN
AY-XPC12CU	
AY-XPC12CQ	
AY-XPC18CU	
AY-XPC18CU-B	